

## Instruction Manual and Replacement Parts List

---

### Breathing Air Purification Systems and Industrial Air Purification Systems

#### **Breathing Air Purification Models**

<b>P0</b>	<b>P1</b>	<b>P2</b>	<b>P4</b>
<b>P5</b>	<b>P10</b>	<b>P31</b>	<b>P41</b>
<b>P42</b>	<b>P43</b>		

**with Securus® Electronic Moisture Monitor System**

<b>P2S</b>	<b>P5S</b>	<b>P10S</b>	<b>P14S</b>
<b>P42S</b>	<b>P43S</b>	<b>P12</b>	<b>P14</b>

#### **Industrial Air Purification Models**

<b>IP41</b>	<b>IP42</b>	<b>IP43</b>
<b>with Securus® Moisture Monitoring System</b>		
<b>IP2S</b>	<b>IP5S</b>	<b>IP10S</b>
<b>IP41S</b>	<b>IP42S</b>	<b>IP43S</b>

April 17, 2013

3rd Edition, Rev 0 Chg 6  
© Bauer Compressors, Inc.

MNL-0096

This information is believed to be accurate by Bauer Compressors, Inc., as of its date of publication, but Bauer offers NO WARRANTY regarding the accuracy, or continuing accuracy, of the information set forth herein. Bauer shall not be liable for inaccuracies in, or consequences resulting from, your use of this information. All information supplied is in connection with sales of Bauer's products, and is thus subject to Bauer's standard terms and conditions of sale. Bauer reserves the right to change this information and has no obligation to update these materials. This information is copyrighted by Bauer Compressors, Inc., and Bauer reserves to itself all rights to this publication. Bauer's customers have no right to reproduce, rewrite, modify, license or permit anyone else's use of this information, without the express written permission of Bauer Compressors, Inc.

**⚠ WARNING**

This Instruction Manual and Replacement Parts List contains safety information and instructions for the Air Purification Systems.

You must read, understand and follow all safety precautions and instructions.

## EDITIONS, REVISIONS AND CHANGES

- An Edition is the original or a complete rewriting of the entire Manual.
- A Revision occurs whenever a complete Section or Appendix is rewritten or added.
- A Change occurs when individual pages, drawings or tables are changed.

### 3rd Edition May 11, 2005

Rev	Chg	Date	Notes	Auth
0	0	May 11, 2005		JD
0	1	Dec. 12, 2005	Changed Manual Condensate Drain Valve to P/N 073793	JD
0	2	Aug. 1, 2006	Corrected Figures 5-1, 5-4, 5-9 & 5-12. Added Figures 5-8 and 5-16.	JD
0	3	Jan. 17, 2007	Add P/N N24788 to P31 Purification System Parts list	JD
0	4	Mar. 19, 2007	Life Span of Oil/Water Separator Lengthened	JD
0	5	July 9, 2010	Updated High Flow Cartridge Removal	SS
0	6	Apr. 17, 2013	Updated P31 Part numbers to B61.1	SS

## Table of Contents

### CHAPTER 1: - - - - - INTRODUCTION

<b>1.1</b>	<b>HOW TO USE THIS MANUAL</b> .....	1
1.1.1	Manual Safety Notices .....	1
<b>1.2</b>	<b>HOW TO USE THE REPLACEMENT PARTS LIST</b> .....	2
<b>1.3</b>	<b>HOW TO USE THE APPENDIX</b> .....	3

### CHAPTER 2: - - - - - PURIFICATION SYSTEM

<b>2.1</b>	<b>INTRODUCTION</b> .....	4
2.1.1	General Purification System Procedures .....	4
2.1.2	Chamber Safety Bore .....	4
2.1.3	Manual Condensate Drainage .....	5
2.1.4	Model, Serial Number and Part Number Identification .....	5
2.1.4.1	Compressor Dataplate.....	5
2.1.4.2	Purification System Dataplate .....	6
2.1.4.3	Cartridge Installation Dataplate.....	6
2.1.5	Breathing Air Purification System Configurations .....	6
2.1.6	Industrial Purification System Configurations .....	7
2.1.7	Cartridge Operating Life .....	7
2.1.7.1	Calculating the Maximum Cartridge Operating Hours .....	8
2.1.7.2	Calculating the Adjusted Cartridge Operating Hours.....	8
2.1.7.3	Air Purification Cartridge Operating Hours Form.....	10

### CHAPTER 3: - - - SINGLE CHAMBER PURIFICATION SYSTEMS

<b>3.1</b>	<b>APPLICABILITY</b> .....	11
<b>3.2</b>	<b>P0 PURIFICATION SYSTEM DESCRIPTION</b> .....	11
3.2.1	Maintenance .....	12
3.2.1.1	Replacing the Cartridge .....	12
3.2.1.2	Chamber Replacement Interval .....	13
3.2.2	Replacement Parts List.....	15
<b>3.3</b>	<b>P31 PURIFICATION SYSTEM</b> .....	17
3.3.1	Major Components .....	17
3.3.2	Configuration Options.....	18
3.3.3	Maintenance .....	19
3.3.3.1	Replacing the Cartridge .....	19
3.3.4	Replacement Parts List.....	20

### CHAPTER 4: - - - - - MULTI-CHAMBER PURIFICATION SYSTEMS

<b>4.1</b>	<b>APPLICABILITY</b> .....	23
<b>4.2</b>	<b>COMPONENTS LAYOUT</b> .....	23
<b>4.3</b>	<b>COMPONENT DESCRIPTION</b> .....	24
4.3.1	Oil and Water Separator .....	24
4.3.2	Chamber .....	25
4.3.3	Cartridge.....	25
4.3.3.1	Cartridge Handling .....	25
4.3.4	Condensate Drain Valve.....	25

4.3.5	Check Valves .....	26
4.3.6	Bleed Valve .....	26
4.3.7	Pressure Maintaining Valve .....	26
4.3.8	Safety Valve .....	26
<b>4.4</b>	<b>MAINTENANCE .....</b>	<b>26</b>
4.4.1	Oil and Water Separator .....	26
4.4.2	Cartridge Replacement .....	27
4.4.2.1	Leaking at the Safety Bore.....	28
<b>4.5</b>	<b>PURIFICATION CARTRIDGE APPLICABILITY .....</b>	<b>29</b>
4.5.1	Purification Chamber Position References.....	29
<b>4.6</b>	<b>PURIFICATION SYSTEM REPLACEMENT PARTS LIST .....</b>	<b>31</b>
4.6.1	P1 Purification System .....	31
4.6.2	P2 Purification System .....	32
4.6.3	P2S and IP2S Purification System .....	33
4.6.4	P4 Purification System .....	34
4.6.5	P5 Purification System .....	35
4.6.6	P5S and IP5S Purification System .....	36
4.6.7	P10 Purification System .....	37
4.6.8	P10S and IP10S Purification System .....	38
4.6.9	P10S II Purification System .....	39
4.6.10	P41 and IP41 Purification System.....	40
4.6.11	P41S and IP41S Purification System .....	41
4.6.12	P42 and IP42 Purification System.....	42
4.6.13	P42S and IP42S Purification System .....	43
4.6.14	P43 and IP43 Purification System.....	44
4.6.15	P43S and IP43S Purification System .....	45
<b>4.7</b>	<b>PURIFICATION COMPONENTS REPLACEMENT PARTS LIST .....</b>	<b>46</b>
4.7.1	Oil and Water Separator, P/N 079416 .....	46
4.7.2	10" Chamber, P/N 080143 .....	47
4.7.3	20" Chamber P/N 082135 .....	48
4.7.4	20" Securus® Chamber P/N 082136.....	49
4.7.5	20" Securus II® Chamber P/N 082136.....	51
4.7.6	27" Chamber P/N 080144 .....	53
4.7.7	27" Securus® Chamber P/N 080145 .....	55
4.7.8	27" Securus II® Chamber P/N 080145 .....	57

**CHAPTER 5:- - - - - HIGH FLOW PURIFICATION SYSTEMS**

<b>5.1</b>	<b>APPLICABILITY .....</b>	<b>59</b>
<b>5.2</b>	<b>P12 PURIFICATION SYSTEM .....</b>	<b>59</b>
5.2.1	Major Components and Configurations .....	59
5.2.1.1	Oil and Water Separator .....	60
5.2.1.2	Condensate Drain Valve .....	60
5.2.1.3	Check Valves .....	60
5.2.1.4	Dryer Cartridge .....	60
5.2.1.5	Bleed Valve.....	60
5.2.1.6	Pressure Maintaining Valve.....	60
5.2.1.7	Safety Valve.....	60
5.2.1.8	Securus® Electronic Moisture Monitor System .....	60
5.2.1.9	Securus® Cartridge .....	60
5.2.1.10	Securus® Indicator.....	60
5.2.2	Maintenance .....	61
5.2.2.1	Oil and Water Separator .....	61

5.2.2.2	Chamber.....	62
5.2.2.3	Cartridge Leaks after Installation .....	63
5.2.3	Replacement Parts List .....	64
<b>5.3</b>	<b>P14 PURIFICATION SYSTEM.....</b>	<b>72</b>
5.3.1	Major Components.....	72
5.3.1.1	Oil and Water Separator .....	73
5.3.1.2	Condensate Drain Valve.....	73
5.3.1.3	Check Valves.....	73
5.3.1.4	Dryer Cartridge.....	73
5.3.1.5	Bleed Valve .....	73
5.3.1.6	Pressure Maintaining Valve.....	73
5.3.1.7	Safety Valve.....	73
5.3.1.8	Securus® Electronic Moisture Monitor System .....	73
5.3.1.9	Securus® Cartridge.....	73
5.3.1.10	Securus® Indicator .....	73
5.3.2	Maintenance .....	74
5.3.2.1	Oil and Water Separator .....	74
5.3.2.2	Chamber.....	75
5.3.2.3	Cartridge Leaks after Installation .....	76
5.3.3	Replacement Parts List .....	77

---

## CHAPTER 6: - - - - - APPENDIX

---

<b>6.1</b>	<b>SAFETY.....</b>	<b>86</b>
6.1.1	General Safety Precautions .....	86
6.1.2	Safety Warning Labels .....	88
<b>6.2</b>	<b>UNPACKING, HANDLING AND INSTALLATION .....</b>	<b>89</b>
6.2.1	Unpacking and Handling.....	89
6.2.2	Installation of the Unit.....	89
6.2.2.1	General.....	89
6.2.2.2	Electrical Installation .....	89
<b>6.3</b>	<b>LONG TERM STORAGE.....</b>	<b>90</b>
6.3.1	General .....	90
6.3.2	Preparations.....	90
6.3.2.1	Units Equipped with a Filter System .....	90
6.3.3	Preserving the Compressor.....	90
6.3.4	Preventive Maintenance During Storage.....	91
6.3.5	Lubrication Oils for Preservation.....	91
6.3.6	Reactivating the Compressor Unit .....	91
<b>6.4</b>	<b>REFERENCE DATA.....</b>	<b>93</b>
6.4.1	Tightening Torque Values.....	93
6.4.2	Torque Sequence Diagrams .....	93
6.4.3	Conversion Formulas .....	93
6.4.4	Approved Lubricants Chart.....	94
6.4.5	Glossary of Abbreviations and Acronyms .....	94
<b>6.5</b>	<b>ADDITIONAL DOCUMENTS .....</b>	<b>95</b>
6.5.1	Diagrams and Drawings.....	95
6.5.2	Other Documents.....	95

**List of Figures**

**CHAPTER 1:- - - - - INTRODUCTION**

Figure 1-1 Compressor Identification Label ..... 2

**CHAPTER 2:- - - - - PURIFICATION SYSTEM**

Figure 2-1 Cartridge Safety Venting ..... 5  
 Figure 2-2 P0 & P31 Safety Venting ..... 5  
 Figure 2-3 Purification System Dataplates (typical) ..... 5  
 Figure 2-4 Correction Factor for Cartridge Operating Hours ..... 9  
 Figure 2-5 Example Record of Adjusted Operating Hours ..... 9

**CHAPTER 3:- - - - SINGLE CHAMBER PURIFICATION SYSTEMS**

Figure 3-1 P0 Purification Chamber ..... 11  
 Figure 3-2 P0 Purification System Cross Section ..... 12  
 Figure 3-3 P0 Purification System ..... 15  
 Figure 3-4 P31 Purification System ..... 17  
 Figure 3-5 P31 Purification System Cross Section ..... 18  
 Figure 3-6 P31 Purification System ..... 20  
 Figure 3-7 P31 Purification System Base Assembly ..... 21  
 Figure 3-8 P31 Purification System Check Valve ..... 22

**CHAPTER 4:- - - - MULTI-CHAMBER PURIFICATION SYSTEMS**

Figure 4-1 Typical Bauer Purification System ..... 23  
 Figure 4-2 Oil and Water Separator ..... 24  
 Figure 4-3 Oil and Water Separator Labels ..... 25  
 Figure 4-4 Oil and Water Separator ..... 27  
 Figure 4-5 Sintered Metal Filter Assembly ..... 27  
 Figure 4-6 Cartridge Replacement ..... 28  
 Figure 4-7 Purification Chamber Position ..... 29  
 Figure 4-8 P1 Purification System ..... 31  
 Figure 4-9 P2 Purification System ..... 32  
 Figure 4-10 P2S and IP2S Purification System ..... 33  
 Figure 4-11 P4 Purification System ..... 34  
 Figure 4-12 P5 Purification System ..... 35  
 Figure 4-13 P5S and IP5S Purification System ..... 36  
 Figure 4-14 P10 Purification System ..... 37  
 Figure 4-15 P10S and IP10S Purification System ..... 38  
 Figure 4-16 P10S II Purification System ..... 39  
 Figure 4-17 P41 and IP41 Purification System ..... 40  
 Figure 4-18 P41S and IP41S Purification System ..... 41  
 Figure 4-19 P42 and IP42 Purification System ..... 42  
 Figure 4-20 P42S and IP42S Purification System ..... 43

---

Figure 4-21	P43 and IP43 Purification System.....	44
Figure 4-22	P43S and IP43S Purification System .....	45
Figure 4-23	Oil and Water Separator, P/N 079416.....	46
Figure 4-24	10” Chamber, P/N 080143 .....	47
Figure 4-25	20” Chamber P/N 082135 .....	48
Figure 4-26	20” Securus® Chamber P/N 082136.....	49
Figure 4-27	20” Securus® Chamber P/N 082136.....	51
Figure 4-28	27” Chamber P/N 080144 .....	53
Figure 4-29	27” Securus® Chamber P/N 080145 .....	55
Figure 4-30	27” Securus II® Chamber P/N 080145 .....	57

---

**CHAPTER 5: - - - - - HIGH FLOW PURIFICATION SYSTEMS**

---

Figure 5-1	P12 Purification System .....	59
Figure 5-2	Oil and Water Separator .....	62
Figure 5-3	Cartridge Replacement .....	63
Figure 5-4	P12 Purification System .....	64
Figure 5-5	Oil and Water Separator .....	65
Figure 5-6	27” High Flow Chamber Assembly .....	67
Figure 5-7	Securus® Chamber Assembly .....	69
Figure 5-8	CO Removal Chamber .....	71
Figure 5-9	P14 Purification System .....	72
Figure 5-10	Oil and Water Separator .....	75
Figure 5-11	Cartridge Replacement .....	76
Figure 5-12	P14 Purification System .....	77
Figure 5-13	Oil and Water Separator .....	79
Figure 5-14	27” High Flow Chamber Assembly .....	81
Figure 5-15	Securus® Chamber Assembly .....	83
Figure 5-16	CO Removal Chamber .....	85

---

**CHAPTER 6: - - - - - APPENDIX**

---

Figure 6-1	Lifting Devices .....	89
Figure 6-2	6 Bolt and 4 Bolt Torque Sequence.....	93

---

## CHAPTER 1: INTRODUCTION

### 1.1 How To Use This Manual

This manual contains the operating and maintenance instructions for the Bauer Compressors, Inc. products listed on the front cover.

All instructions in this manual should be observed and carried out as written to prevent damage or premature wear to the product or the equipment served by it.

If your unit is equipped with nonstandard accessories and or options, supplemental information is normally included in other documentation; i.e. OEM Manuals or additional Bauer Manuals.

While every effort is made to ensure the accuracy of the information contained in this manual, Bauer Compressors, Inc. will not, under any circumstances be held accountable for any inaccuracies or the consequences thereof.

#### 1.1.1 Manual Safety Notices

Important instructions concerning the endangerment of personnel, technical safety or operator safety will be specially emphasized in this manual by placing the information in the following types of safety notices.

#### **DANGER**

DANGER indicates an imminently hazardous situation which, if not avoided, will result in death or serious injury. This is limited to the most extreme situations.

#### **WARNING**

WARNING indicates a potentially hazardous situation which, if not avoided, could result in death or injury.

#### **CAUTION**

CAUTION indicates a potentially hazardous situation which, if not avoided, may result in minor or moderate injury. It may also be used to alert against unsafe practices.

#### **NOTICE**

NOTE advise of technical requirements that require particular attention by the operator or the maintenance technician for proper maintenance and utilization of the equipment.



**1.2 How to Use the Replacement Parts List**

- A lozenge ♦ in the Item Number column indicates the part number for a complete assembly.
- a dagger (†) in the Qty column with or without an ellipse (...) in the Part Number column means the part is illustrated for assembly purposes only and is not available for sale as an individual component. This part can be obtained by ordering the complete assembly.
- AR in the Qty column means that the item is cut or manufactured to the size which the customer specifies.
- A dash (—) in the Item Number column indicates that there is more than one part number applicable to the preceding Item Number.
- The letters in the columns labeled Kit indicate the number of operating hours when the part is to be replaced; a = replaced every 1,000 hours, b = replaced every 2,000 hours and c= replaced every 4,000 hours.
- NS in the Item Number column indicates the part is not illustrated but is available.

When placing an order for spare parts, please provide the following information to ensure delivery of the correct parts. The model number, date of manufacture and serial number can be found of the compressor unit identification plate on the compressor unit frame.

Information	Example
Model Number	VC 120
Serial Number	143156
Date of Manufacture	02/2013
Part Number	VAL-0500
Part Description	Valve
Part Quantity Required	1

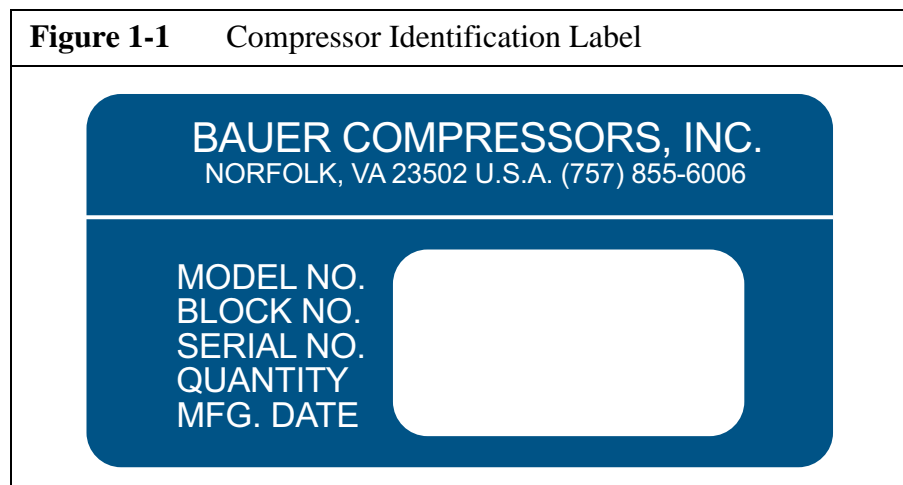

**⚠ WARNING**

The use of repair parts other than those included in the Bauer Replacement Parts Lists may create unsafe conditions over which Bauer has no control. Such unsafe conditions can lead to accidents that may be life-threatening, cause substantial bodily injury, and/or result in damage to the equipment. Therefore, Bauer Compressors, Inc. can bear no responsibility for equipment in which unapproved repair parts are installed.

**1.3 How to Use the Appendix**

Information contained in the Appendix to this manual includes the following.

- The safety instructions applicable to this product. They must be read, understood and complied with prior to operating the product.
- The instructions for installing this product. They must be read, understood and complied with prior to operating the product.
- Reproducible Forms
- Reference Data
  - Torque Values
  - Torque Sequence
  - Conversion Formulas
  - Approved Lubricants
  - Glossary of Abbreviations & Acronyms
- Additional Documents

## CHAPTER 2: PURIFICATION SYSTEM

### 2.1 Introduction

The purpose of all Bauer breathing air purification systems is to remove carbon monoxide, oil, water, taste and odor from the compressed air stream before final delivery.

The purpose of all Bauer industrial air purification systems is to remove oil and water from the compressed air stream before final delivery.

#### **WARNING**

Industrial Air Purification System cartridges do not remove Carbon Monoxide and must not be used in breathing air applications.

The quality of gas produced by the compressor is directly related to the quality and temperature of the gas taken in by the unit. Intake gas should as close as possible to 50 °F (10 °C) and cleanest available and as dry as possible. Bauer compressors normally add approximately 18 °F (10 °C) to the intake gas temperature. The purification cartridges perform their best at approximately 68 °F (20 °C). Adequate ventilation enhances the quality and life of the purification cartridges.

#### 2.1.1 General Purification System Procedures

1. Keep an accurate record of operating hours to ensure exact attention to maintenance intervals
2. Change all cartridges before reactivating a compressor unit that has been out of service more than three months. Leave cartridges in the unit as long as it is out of service.
3. While out of service keep all condensate drain valves closed. Maintain a pressure of 700 - 1,100 psi (50 to 80 bar) within the system to prevent moisture from entering the compressor and purification system.

#### 2.1.2 Chamber Safety Bore

The chambers in all Bauer purification systems are designed to prevent pressurization if the cartridge is missing, not seated properly or damaged (Figure 2-1 & Figure 2-2). Without a cartridge properly in place the safety bore is not sealed, the air escapes into the atmosphere, no pressure can be built up and thus it is ensured that unfiltered air is not supplied to the consuming device. If air is escaping from the safety bore remove and check cartridge. If necessary replace the cartridge or O-rings.

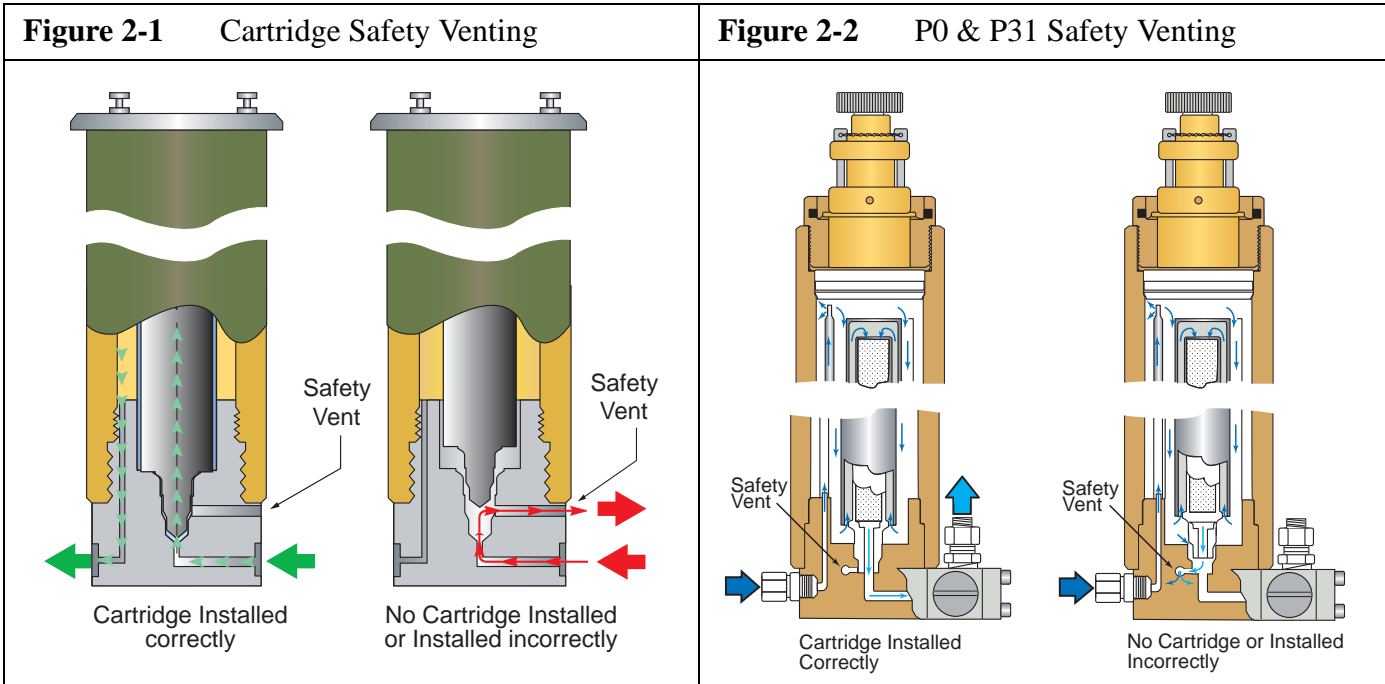

**2.1.3 Manual Condensate Drainage**

The condensate must be drained from the oil and water separator before changing any cartridge, before beginning each filling procedure and in the absence of an Automatic Condensate Drain (ACD) system, every fifteen minutes during the filling procedure. This is done by slowly opening the condensate drain valves. They are opened approximately 1/3 of a turn to the left and held open until the condensate is completely drained. The condensate drain valves close by spring pressure but if necessary may be tightened by hand to ensure they are completely air tight.

**2.1.4 Model, Serial Number and Part Number Identification**

**2.1.4.1 Compressor Dataplate**

The model number, date of manufacture and serial number can be found on the compressor unit identification plate in the main electrical enclosure and frame.

<b>Figure 2-3</b> Purification System Dataplates (typical)																									
Purification System	Cartridge Installation																								
<table style="width: 100%; border: 1px solid black;"> <tr> <td style="text-align: center;">PURIFICATION SYSTEM</td> <td style="text-align: center;"></td> </tr> <tr> <td>MODEL NO.</td> <td><input style="width: 100%;" type="text"/></td> </tr> <tr> <td>MAX. PRESSURE</td> <td><input style="width: 80%;" type="text"/> psig</td> </tr> <tr> <td>AIR PROCESSED</td> <td><input style="width: 80%;" type="text"/> cu. ft.</td> </tr> <tr> <td>O-RING</td> <td><input style="width: 80%;" type="text"/></td> </tr> <tr> <td>BACK-UP RING</td> <td><input style="width: 80%;" type="text"/></td> </tr> <tr> <td colspan="2" style="text-align: right;">LBL-0191</td> </tr> </table>	PURIFICATION SYSTEM		MODEL NO.	<input style="width: 100%;" type="text"/>	MAX. PRESSURE	<input style="width: 80%;" type="text"/> psig	AIR PROCESSED	<input style="width: 80%;" type="text"/> cu. ft.	O-RING	<input style="width: 80%;" type="text"/>	BACK-UP RING	<input style="width: 80%;" type="text"/>	LBL-0191		<table style="width: 100%; border: 1px solid black;"> <tr> <td style="text-align: center;">CARTRIDGE TO BE INSTALLED</td> <td style="text-align: center;"></td> </tr> <tr> <td>CARTRIDGE FOR</td> <td><input style="width: 80%;" type="text"/></td> </tr> <tr> <td>CARTRIDGE NO.</td> <td><input style="width: 80%;" type="text"/></td> </tr> <tr> <td colspan="2" style="text-align: center; font-size: small;">                     1328 Azalea Garden Road - Norfolk Virginia 23502-1944                      Phone: (757) 855-6006 Fax: (757) 855-8224                 </td> </tr> <tr> <td colspan="2" style="text-align: right;">LBL-0044</td> </tr> </table>	CARTRIDGE TO BE INSTALLED		CARTRIDGE FOR	<input style="width: 80%;" type="text"/>	CARTRIDGE NO.	<input style="width: 80%;" type="text"/>	1328 Azalea Garden Road - Norfolk Virginia 23502-1944 Phone: (757) 855-6006 Fax: (757) 855-8224		LBL-0044	
PURIFICATION SYSTEM																									
MODEL NO.	<input style="width: 100%;" type="text"/>																								
MAX. PRESSURE	<input style="width: 80%;" type="text"/> psig																								
AIR PROCESSED	<input style="width: 80%;" type="text"/> cu. ft.																								
O-RING	<input style="width: 80%;" type="text"/>																								
BACK-UP RING	<input style="width: 80%;" type="text"/>																								
LBL-0191																									
CARTRIDGE TO BE INSTALLED																									
CARTRIDGE FOR	<input style="width: 80%;" type="text"/>																								
CARTRIDGE NO.	<input style="width: 80%;" type="text"/>																								
1328 Azalea Garden Road - Norfolk Virginia 23502-1944 Phone: (757) 855-6006 Fax: (757) 855-8224																									
LBL-0044																									

### 2.1.4.2 Purification System Dataplate

Refer to the compressor unit purification system data plate (Figure 2-3) on the compressor front to determine your purification system model and specifications.

### 2.1.4.3 Cartridge Installation Dataplate

The function performed by each chamber in the purification system is determined by the type of cartridge installed in that chamber. Refer to the cartridge installation data plate on the chamber to determine the purpose and part number of the cartridge installed in that chamber. (Figure 2-3).

## 2.1.5 Breathing Air Purification System Configurations

Purification System	Number and Type of Cartridges			Processing Capacity cubic ft (ft) <sup>3</sup>
	Dryer	Purification	Securus®	
P0	Combined			3,200
P1	...	1	...	15,000
P2	...	1	...	40,000
P2 with Securus®	...	...	1	67,000
P4	1	1	...	60,000
P5	1	1	...	90,000
P5 with Securus®	1	...	1	150,000
P10	2	1		140,000
P10 with Securus®	2	...	1	230,000
P12 <sup>a</sup>	1	1		420,000
P14 <sup>a</sup>	2	1		650,000
P31	Combined			11,760
P41	...	1		28,700
P41 with Securus®	...	...	1	47,000
P42	1	1	...	64,000
P42 with Securus®	1	...	1	107,000
P43	2	1	...	100,000
P43 with Securus®	2	...	1	164,000
P81	1	1		124,000
P81 with Securus®	1	...	1	198,000

a. P12 and P14 have the Securus® Electronic Moisture Monitor System as standard equipment.

### 2.1.6 Industrial Purification System Configurations

Purification System	Number and Type of Cartridges			Processing Capacity cubic ft (ft) <sup>3</sup>
	Dryer	Purification	Securus®	
P0	Combined			3,200
P1	...	1	...	15,000
P2	...	1	...	40,000
IP2 with Securus®	...	...	1	67,000
P4	1	1	...	60,000
P5	1	1	...	90,000
IP5 with Securus®	1	...	1	150,000
P10	2	1	...	140,000
IP10 with Securus®	2	...	1	230,000
P31	Combined			11,760
IP41 with Securus®	...	...	1	47,000
IP42 with Securus®	1	...	1	107,000
IP43 with Securus®	2	...	1	164,000

### 2.1.7 Cartridge Operating Life

Every Bauer Purification System is designed to process a certain volume of air before the cartridges require replacement. By using special test equipment that measures the quality of air at the outlet any quality reduction may be detected. However as most compressor owners do not have this test equipment the recommended method of determining cartridge operating life is to maintain a written record of the volume of air processed by the purification system.

Each Bauer compressor block is rated to produce a standard volume of air per minute and by using this number and the air processing capability of the purification system it is possible to calculate the maximum operating hours before the cartridges need to be replaced. See Paragraph 2.1.7.1 for the method of determining this figure.

The ambient air temperature and its ability to cool the compressor will effect the operating life of the cartridge. See Paragraph 2.1.7.2 for the method of calculating this adjustment factor.

The optimum place to measure the temperature is at the inlet to the final separator as this best reflects the temperature of the air as it enters the chambers. Experience has shown that this temperature is approximately 18 °F above the ambient temperature. Therefore for the purpose of calculating cartridge operating life use the Ambient Air Temperature plus 18 °F.

A form titled Air Purification Cartridge Operating Hours is found in Paragraph 2.1.7.3 and in the Appendices. It is used for recording the ambient temperature, operating time and adjustment factor. It

is suggested that it be copied, placed in a protective folder and kept with the unit to record the adjusted operating hours. An example of how this form is used is shown in Figure 2-5.

#### **2.1.7.1 Calculating the Maximum Cartridge Operating Hours**

1. From the purification system data plate (See Figure 2-3) on the purification chamber determine the Air Processed (cu.ft.)
2. From the paragraph titled Compressor Specifications in the instruction manual for your compressor unit determine the Charging Rate in SCFM of your compressor.
3. Divide the Air Processed by the Charging Rate to obtain the Maximum Operating Time in minutes
4. Divide the Maximum Operating Time in minutes by 60 to obtain the Maximum Operating Hours.
5. Record the answer on the Air Purification Cartridge Operating Hours form.

#### **2.1.7.2 Calculating the Adjusted Cartridge Operating Hours**

1. Using the Air Purification Cartridge Operating Hours form record the Date, Operating Hours and Ambient Air Temperature plus 18 °F.
2. Using either the graph or the chart in Figure 2-4 determine the Correction Factor.
3. Divide the Operating Hours by the Correction Factor and record it under the column labeled Today.
4. Add the hours recorded in Today to the previous Total and record it as the current Total.
5. When the Total approaches the Maximum Operating Hours replace the Cartridges.

**Figure 2-4** Correction Factor for Cartridge Operating Hours

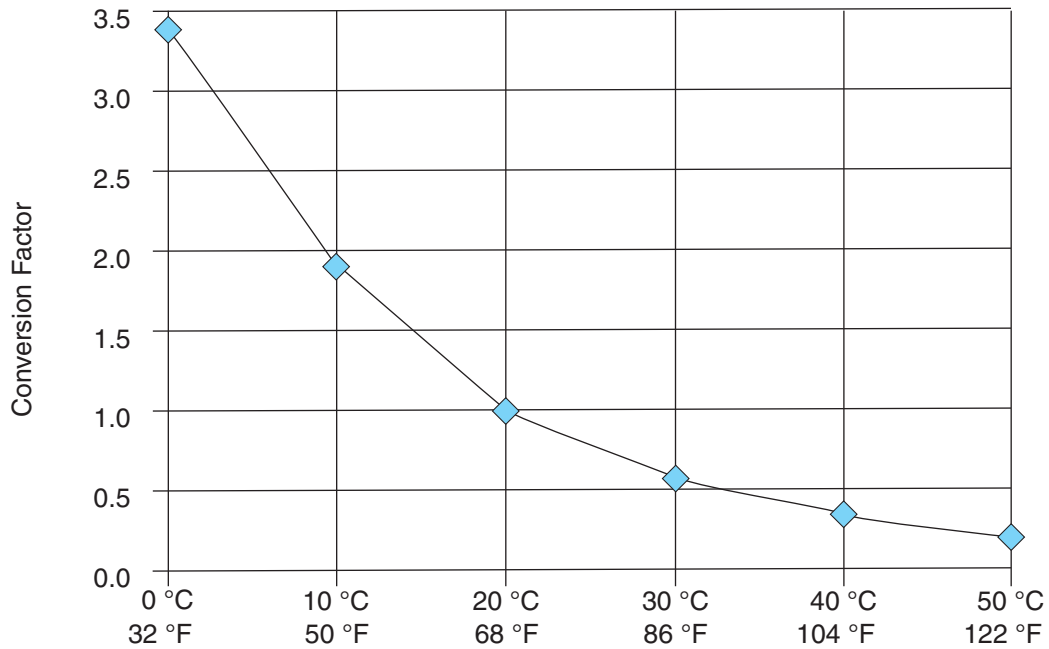

°C [(°F - 32) x 5/9]	°F [°C x 9/5 + 32]	Correction Factor
50	122	0.21
40	104	0.34
30	86	0.58
20	68	1.00
10	50	1.81
0	32	3.44

**Figure 2-5** Example Record of Adjusted Operating Hours

Date	Operating Hours	Ambient Temp. during Compression +18 °F	Correction Factor	Adjusted Cartridge Hours	
				Today	Total
10/19/04	8	92°F (33 °C)	0.5	16.00 $\left( \frac{\text{Op hrs}}{\text{Corr. factor}} \right)$	16.00
11/01/04	4	45°F (7.2 °C)	2.25	1.78	$\left( \frac{\text{Total hrs}}{\text{+Today hrs}} \right)$ 17.78





**CHAPTER 3: SINGLE CHAMBER PURIFICATION SYSTEMS**

**3.1 Applicability**

This chapter applies to Bauer Purification Systems P0 and P31 Only.

**3.2 P0 Purification System Description**

The P0 Purification System consists of a separator and a cartridge chamber. In the separator surrounding the cartridge chamber, liquid oil and water particles are separated from the compressed air by a pipe nozzle. Residual oil and water particles are then removed by the filter cartridge and the air leaving the P0 Purification System is free of water, oil, taste and smell.

**Figure 3-1** P0 Purification Chamber

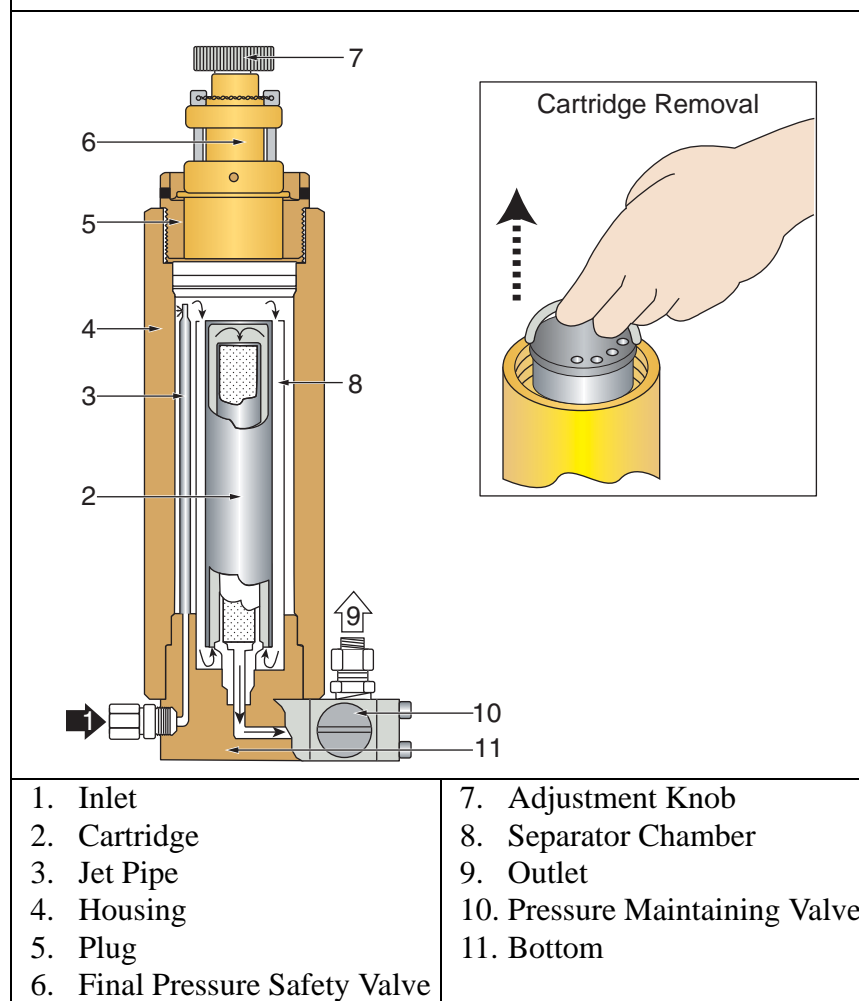

**Figure 3-2 P0 Purification System Cross Section**

### 3.2.1 Maintenance

#### 3.2.1.1 Replacing the Cartridge

See Figure 3-2

1. Depressurize system before starting any maintenance, by opening the condensate drain valve and bleed valve.
2. Unscrew plug (5) on top of the housing (4).
3. Extract old cartridge. (2)
4. Dry inside of the housing (4) with a clean cloth. Check for corrosion. Replace if necessary.
5. Lubricate all threads and O-rings on both the Plug (5) and the Cartridge (2) with petroleum jelly.
6. Insert new cartridge and secure in place with plug (5).

**NOTICE**

The used filter cartridge must be disposed of in accordance with local regulations.

**3.2.1.2 Chamber Replacement Interval****⚠ WARNING**

The P0 Purification System is subject to dynamic loading. It is designed for a certain number of load cycles. A load cycle equates to an abrupt pressure loss caused by draining the condensate. The P0 Purification System must be replaced after reaching the maximum number of load cycles, otherwise the housing may fail due to material fatigue.

The maximum number of load cycles for the P0 Purification Assembly is 45,000 if operated at 5,000 psi (300 bar) or 63,000 if operated at 3,200 psi (225 bar).

If the number of load cycles of four per hour (i.e. the condensate is drained every fifteen minutes) is not exceeded then the maximum number of operating hours before the P0 Purification System must be replaced is 11,125 hours at 5,000 psi (300 bar). To avoid exceeding the maximum number of load cycles the operating hours should always be recorded.



3.2.2 Replacement Parts List

Figure 3-3 P0 Purification System

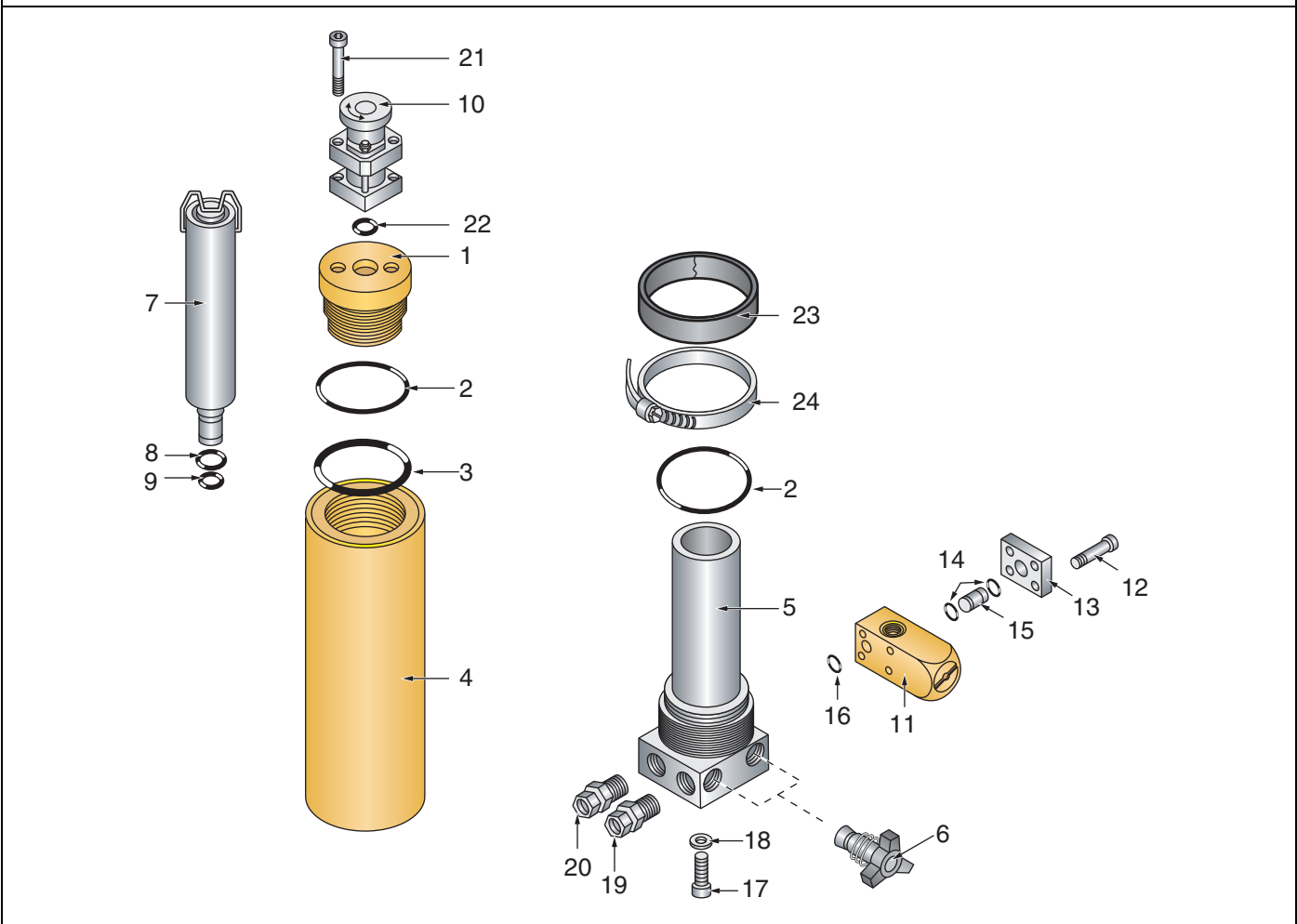

Item	Qty	Part No.	Description	Notes
◇	1	077159-D-V001	P0 Purification System	
1	†	...	Plug	Available only with 077159-D-V001
2	2	N4586	O-ring	
3	1	N25212	O-ring	
4	†	...	Housing	Available only with 077159-D-V001
5	†	...	Bottom	Available only with 077159-D-V001
6	1	073793	Condensate Drain Tap Assembly	
7	1	059183A	Cartridge Assembly	Includes Items 9 and 10
8	1	N4566	O-ring	
9	1	N3824	O-ring	
10	1	059410	Safety Valve	
11	1	077235	Pressure Maintaining Valve	
12	4	SCR-0177	Socket Head Cap Screw	

**Figure 3-3 (cont.)** P0 Purification System

<b>Item</b>	<b>Qty</b>	<b>Part No.</b>	<b>Description</b>	<b>Notes</b>
13	1	57937	Cover	
14	2	N16591	O-ring	
15	1	57904	Connection Pipe	
16	1	N24788	O-ring	
17	2	N19547	Allen Screw	
18	2	WAS-0021	Washer	
19	1	N24910	Male Connector	
20	1	N20287	Male Connector	
21	4	SCR-0139	Allen Screw	
22	1	N4882	O-ring	
23	1	073093	Rubber Wrap	
24	1	CMP-0075	Clamp	

### 3.3 P31 Purification System

#### 3.3.1 Major Components

The P31 purification system assembly consists of a separator and a cartridge chamber. In the separator liquid oil and water particles are separated from the compressed air by a pipe nozzle. Residual oil and water particles are then removed by the filter cartridge and the air leaving the filter assembly is free of oil, taste and smell.

**Figure 3-4** P31 Purification System

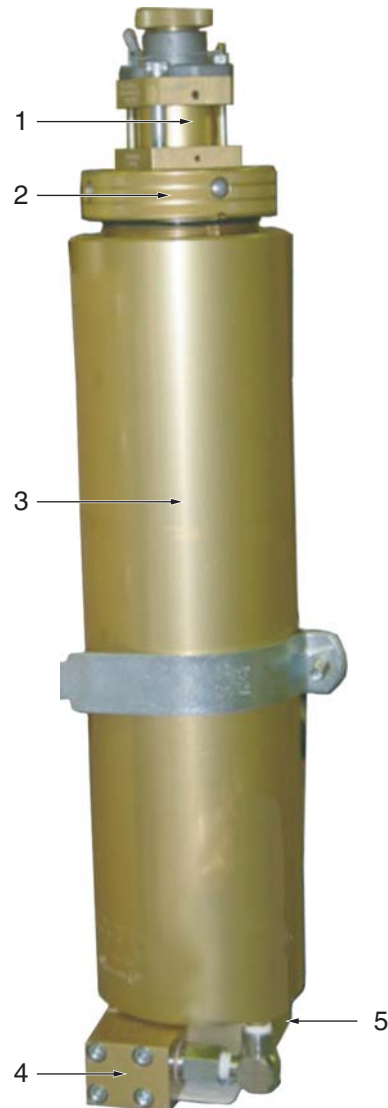

1. Final Safety Valve  
2. Plug  
3. Housing

4. System Check Valve  
5. Bottom



### 3.3.2 Configuration Options

On some models the P31 Purification system can be specified at the time of purchase as a factory installed option and may not be installed on your unit.

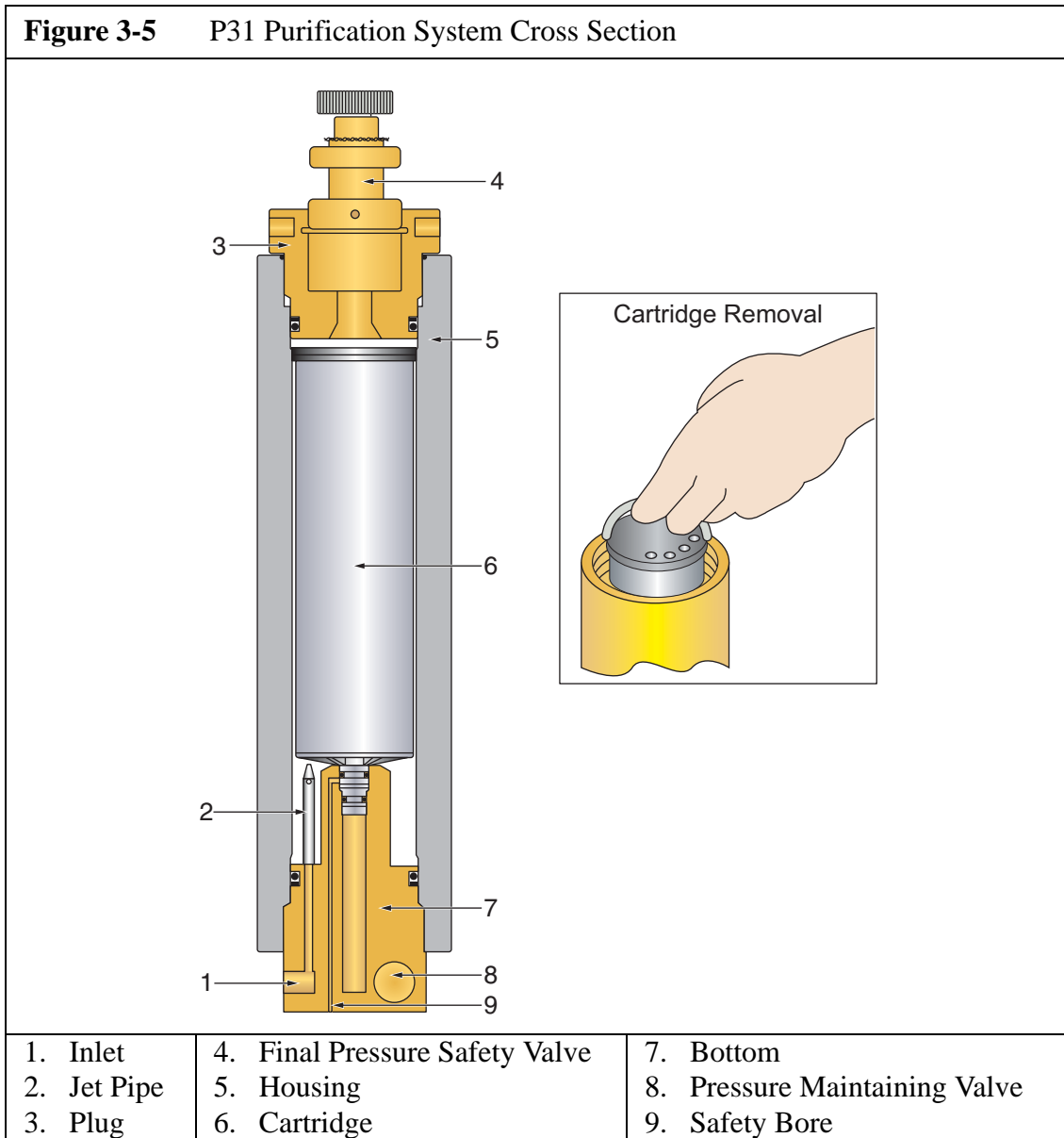

### 3.3.3 Maintenance

#### 3.3.3.1 Replacing the Cartridge

1. Depressurize system before starting any maintenance, by opening the condensate drain valve.
2. Unscrew plug (3) on top of the filter.
3. Extract old cartridge. (6)
4. Dry inside of the housing (5) with a clean cloth. Check for corrosion. Replace if necessary.
5. Lubricate threads, O-rings and threaded portion of replacement cartridge with petrolatum.
6. Insert new cartridge and secure in place with plug (3).

#### NOTICE

The used filter cartridge must be disposed of in accordance with local, State, and Federal regulations.

#### 3.3.3.1.1 Chamber Replacement Interval

#### WARNING

The P31 Filter System is subject to dynamic loading. It is designed for a certain number of load cycles. A load cycle equates to an abrupt pressure loss caused by draining the condensate. The filter assembly must be replaced after reaching the maximum number of load cycles, otherwise the housing may fail due to material fatigue.

The maximum number of load cycles for the P31 filter assembly is 6,500 if operated at 5,000 psi (300 bar) or 20,000 if operated at 3,200 psi (225 bar).

If the number of load cycles of four per hour (i.e. the condensate is drained every fifteen minutes) is not exceeded then the maximum number of operating hours before the filter must be replaced is 11,625 hours at 5,000 psi (300 bar). To avoid exceeding the maximum number of load cycles the operating hours should always be recorded.

3.3.4 Replacement Parts List

Figure 3-6 P31 Purification System

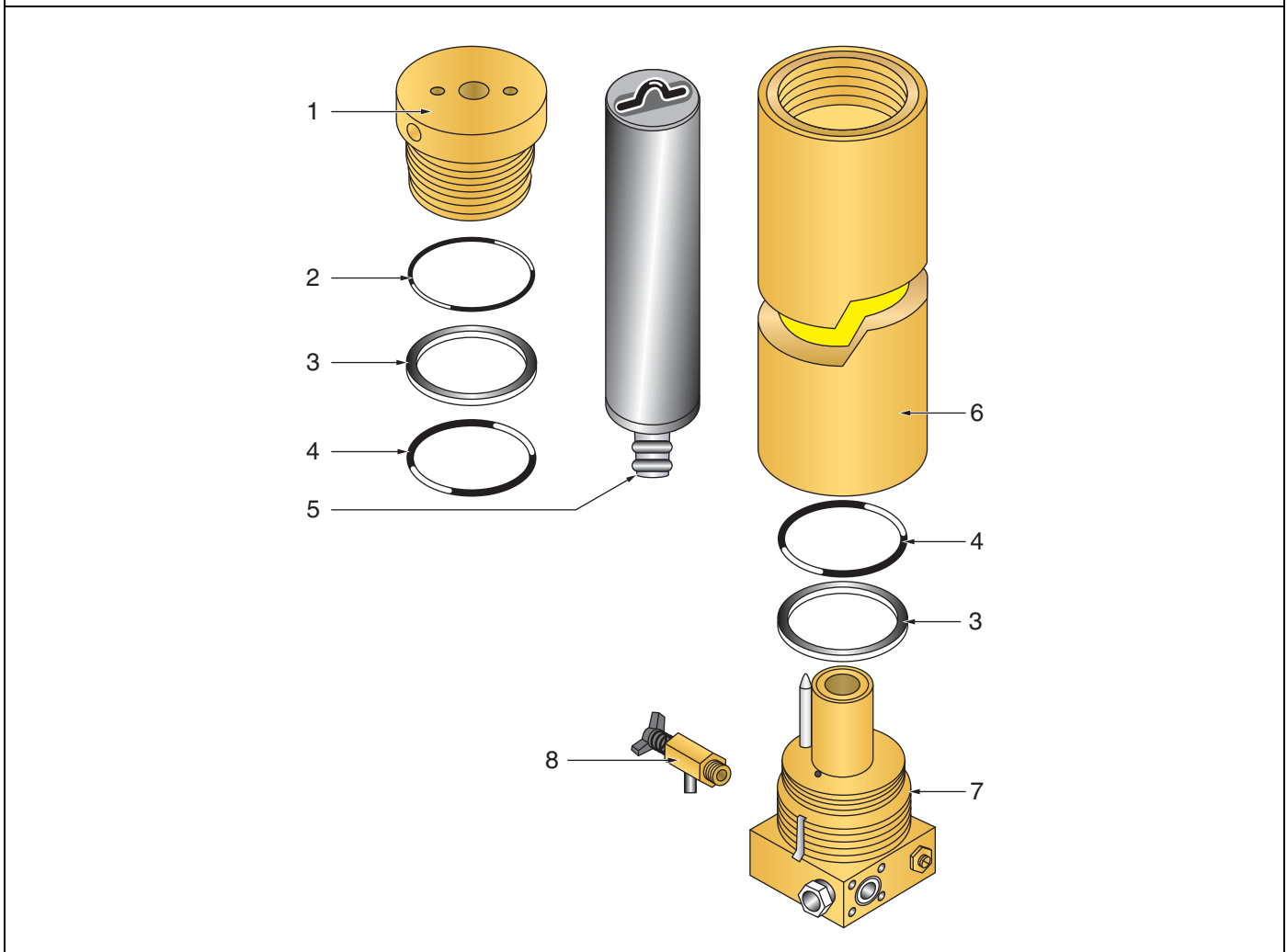

Item	Qty	Part No.	Description	Notes
◇	1	082374	P31 Filter System	
1	1	80060	Plug	Available only with 082374
2	1	N4784	O-ring	
3	2	N4736	Backup Ring	
4	2	N4735	O-ring	
5	1	080100A	Filter Cartridge	MS-AC
or	1	080114A	Filter Cartridge	MS-AC-HP
6	1	80066	Filter Housing	Available only with 082374
7	1	80593	Filter Base Assembly	See Figure 3-7
8	1	011430	Condensate Drain Tap Assembly	

**Figure 3-7** P31 Purification System Base Assembly

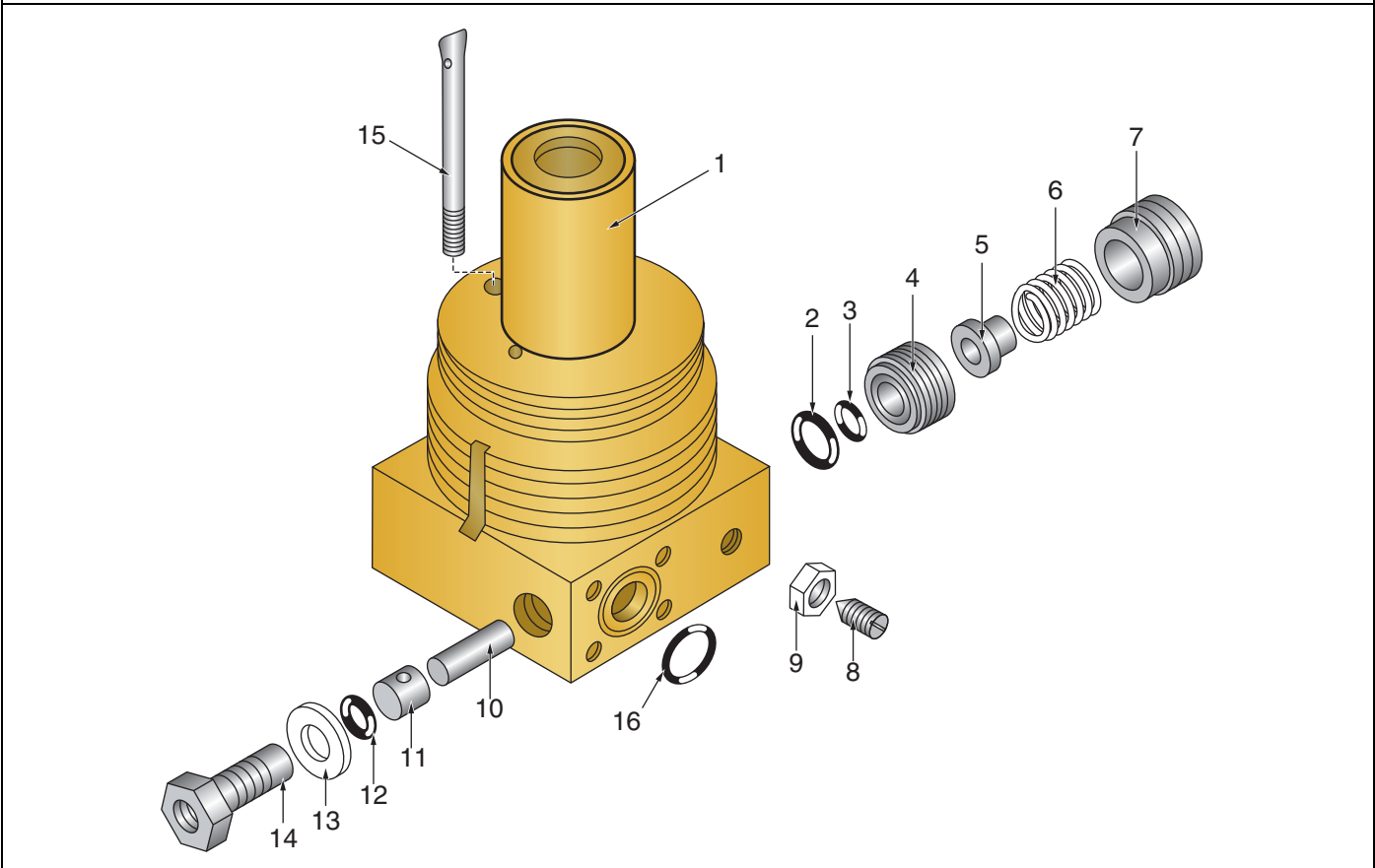

Item	Qty	Part No.	Description	Notes
◇	1	80593	Filter Base Assembly	
1	1	80068	Base	Available only with 082374
2	1	N24927	O-ring	
3	1	N25503	O-ring	
4	1	78536	Seat	Available only with 082374
5	1	79199	Seat Spring	Available only with 082374
6	1	2623	Spring	
7	1	57935	Adjusting Screw	Available only with 082374
8	1	N27297	Set Screw	
9	1	N3837	Hex Nut	
10	1	78106	Cylindric Pin	
11	1	78688	Valve Piston	
12	1	N23166	O-ring	
13	1	4602	Backup Ring	
14	1	91038	Valve Seat	
15	1	80603	Nozzle	Available only with 082374
16	1	N24788	O-ring	

**Figure 3-8** P31 Purification System Check Valve

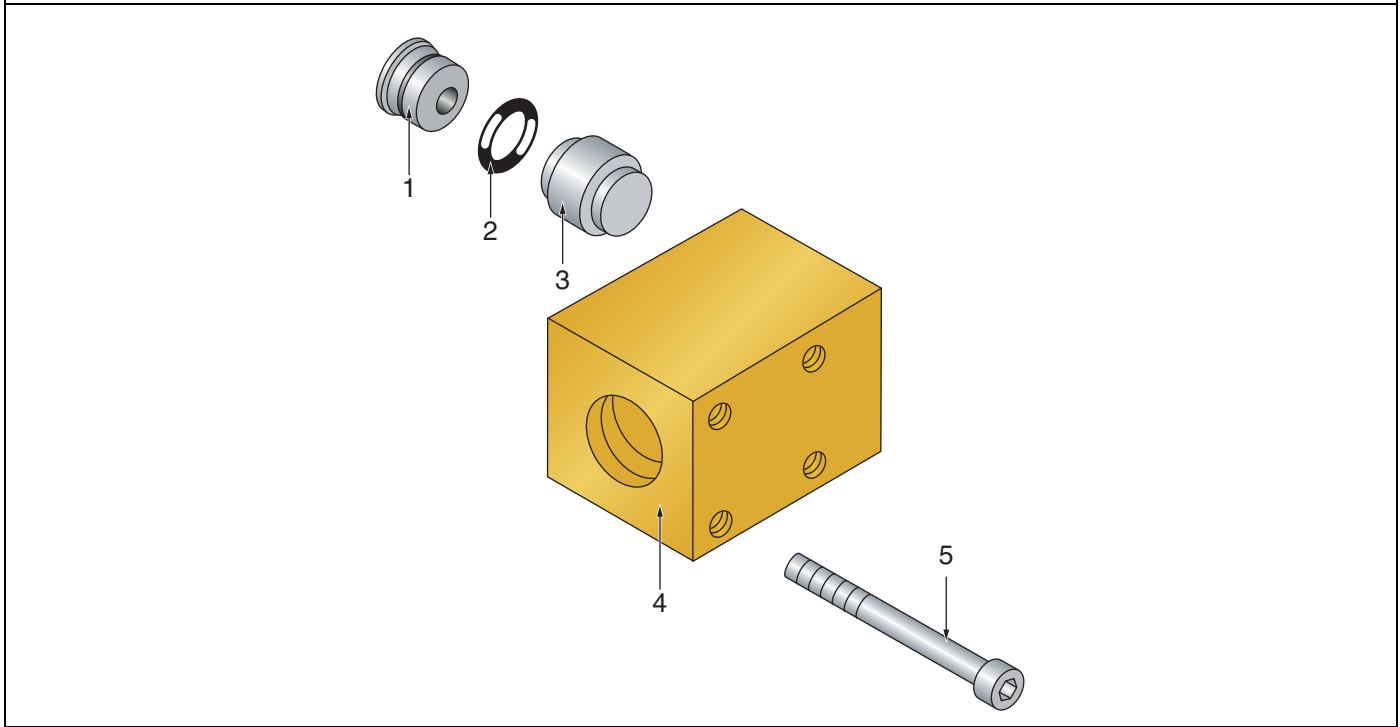

Item	Qty	Part No.	Description	Notes
◇	1	80555	Check Valve	
1	1	80716	Valve Seat	
2	1	N29166	O-ring	
3	1	73767	Valve Piston	
4	1	80552	Valve Housing	
5	4	N19539	Allen Screw	

**CHAPTER 4: MULTI-CHAMBER PURIFICATION SYSTEMS**

**4.1 Applicability**

This chapter applies to these Bauer Purification System models: P1, P2, P2S, IP2S, P4, P5, P5S, IP5S, P10, P10S, IP10S, P41,P41S, IP41, IP41S, P42, P42S, IP42, IP42S, P43, P43S, IP43 and IP43S.

**4.2 Components Layout**

The minimum components of all Bauer Air Purification Systems are a Oil and Water Separator and a Purification Chamber. Different models add one or more Dryer Chambers and replace the Purification Chamber with a Securus® Electronic Moisture Monitor System Purification Chamber. Additional components generally include a Condensate Drain Valve, Check Valves, a Bleed Valve, a Pressure Maintaining Valve, and a Safety Valve. Figure 4-1 shows the typical interconnection of these components.

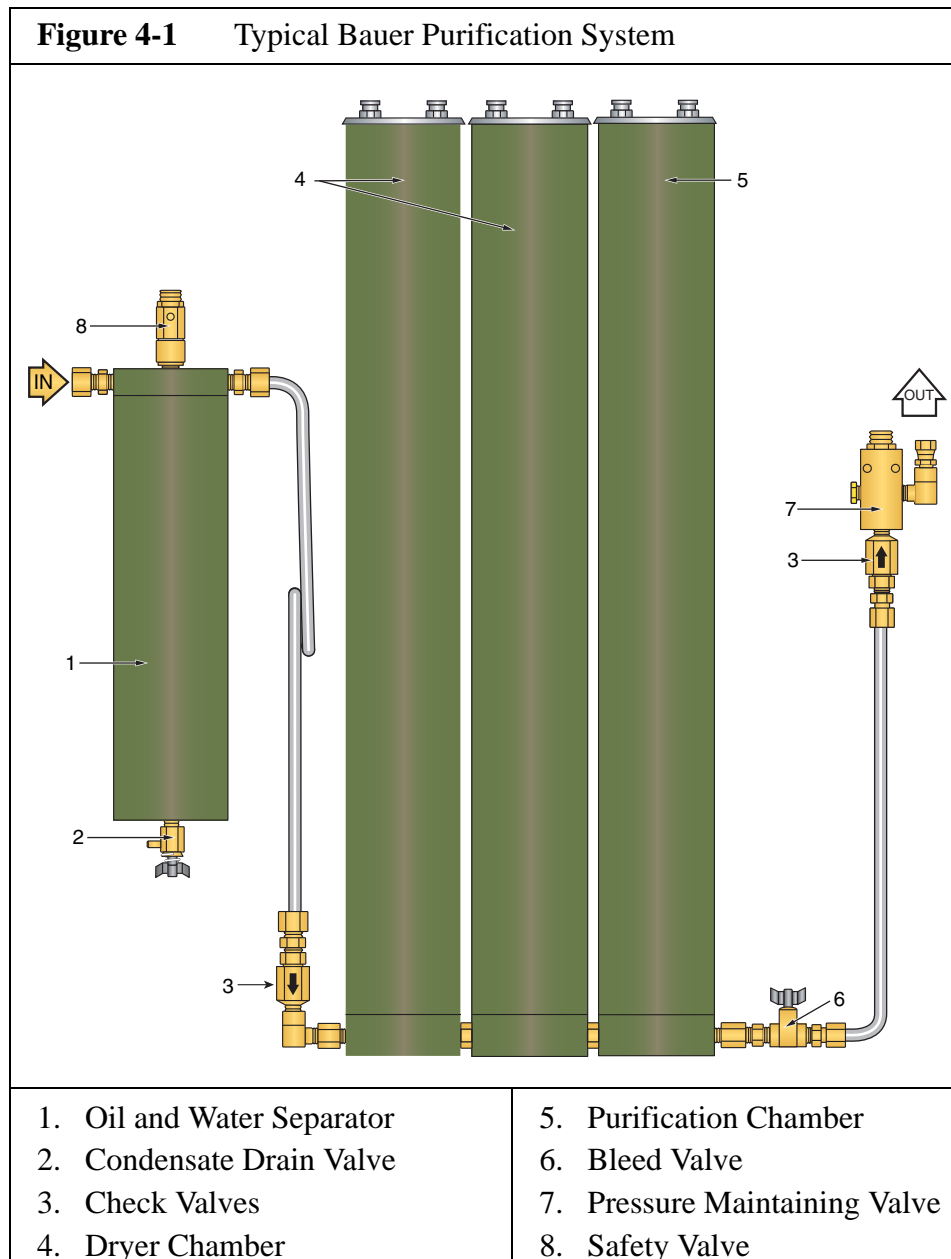

### 4.3 Component Description

#### 4.3.1 Oil and Water Separator

**Figure 4-2** Oil and Water Separator



The air leaving the compressors' final stage is cooled in the aftercooler to approximately 18 - 27 °F (10-15 °C) above ambient temperature and then enters the oil and water separator. The oil and water separator works by means of a sintered metal filter which separates liquid oil and water particles from the compressed air. This oil and water mixture is then drained, either automatically by a Automatic Condensate Drain System or manually by the Condensate Drain Valve.

#### **⚠ WARNING**

The rapid depressurizing and repressurizing of the oil and water separator during condensate draining subjects it to metallurgical stresses. To prevent catastrophic failure with the possibility of damage, injury or death the oil and water separator (P/N 079416) must be replaced after a predetermined number of cycles. One load cycle equals one pressurization plus one depressurization.

Units operating between 3,000 and 5,000 psi = 130,000 load cycles (32,500 hours of operation)

Units operating between 5,000 and 6,000 psi = 55,000 load cycles (13,750 hours of operation)

The Bauer recommended frequency of condensate draining is every fifteen minutes and is a balance between maximizing the life of the separator chamber and maintaining the quality of the delivered air.

**Figure 4-3** Oil and Water Separator Labels



**4.3.2 Chamber**

Each chamber is made up of an anodized aluminum housing and a filtering cartridge. There are two general types of filtering cartridges, drying or purifying. The cartridge type is determined by the ingredients packed in the cartridge. The chamber is named after the type of cartridge it contains, i.e. dryer chamber or purification chamber.

**4.3.3 Cartridge**

The cartridge casing, top and bottom are aluminum and are packed with one or more of the following.

1. Molecular sieve to absorb oil and water.
2. Activated carbon which absorbs oil vapors effecting taste and odor.
3. A catalyst to convert carbon monoxide to carbon dioxide.
4. A sensor for the Securus Electronic Moisture Monitor System.

**4.3.3.1 Cartridge Handling**

1. Never open the protective packaging a cartridge comes in prior to its actual use. The highly sensitive filter materials will absorb moisture from the atmosphere becoming saturated and useless.
2. Used cartridges must be disposed of in accordance with local regulations.

**4.3.4 Condensate Drain Valve**

A manually operated valve used for maintenance and before start-up to drain the condensed liquids from the coalescing oil and water separator.





### **4.3.5 Check Valves**

Check valves allow compressed air to flow in only one direction. One is used to maintain pressure in the chamber when the compressor is not operating. The other check valve prevents flow from filled storage cylinders or tanks back into the purification system and compressor.

### **4.3.6 Bleed Valve**

A manually operated valve used to release the pressure in the chambers before maintenance.

### **4.3.7 Pressure Maintaining Valve**

The pressure maintaining valve ensures that pressure is built up in the purification system from the start of delivery, thus achieving constant optimum purification. It also assures proper working conditions for the final stage of compression.

### **4.3.8 Safety Valve**

The safety valve is located on the coalescing oil and water separator and acts as the safety valve for the final stage of the compressor.

## **4.4 Maintenance**

### **4.4.1 Oil and Water Separator**

To remove the sintered metal filter proceed as follows: (See Figure 4-4)

1. Disconnect the power and shut off the inlet supply line if applicable.
2. Depressurize the system by means of the bleed valve.
3. Remove the tubes connected to the side of the filter head (1).
4. Unscrew and remove the filter head.
5. Unscrew the sintered metal filter assembly (2) from the filter head.
6. Remove the center screw (3) to disassemble the sintered metal filter assembly.
7. Clean the sintered metal filter using hot soapy water. Blow dry with compressed air.
8. After cleaning the element, record the number of operating hours to ensure exact attention to the maintenance intervals.
9. Lubricate the threads and O-rings as well as the threaded part of the sintered metal filter with petroleum jelly. Apply sparingly.
10. Dry the inside of the filter housing with a clean cloth and check for corrosion.
11. In the event you discover corrosion, replace the corroded parts with new BAUER parts.
12. Reinstall the sintered metal filter assembly and filter head.
13. Replace all removed tubes, close all valves and check for leaks.

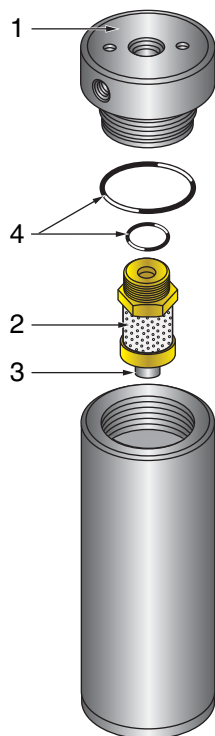
**Figure 4-4** Oil and Water Separator

- |                          |                 |
|--------------------------|-----------------|
| 1. Filter Head           | 3. Center Screw |
| 2. Sintered Metal Filter | 4. O -rings     |

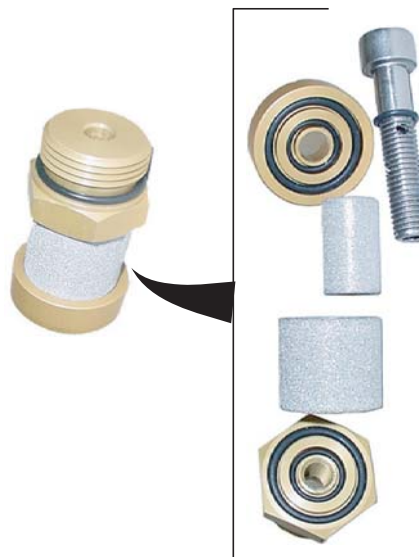
**Figure 4-5** Sintered Metal Filter Assembly

#### 4.4.2 Cartridge Replacement

To change the cartridge, proceed as follows. (See Figure 4-6) Disconnect the power and shut off the inlet supply line, if applicable.

1. Depressurize the system by means of the bleed valve.
2. Unscrew the chamber head using the special wrench supplied.
3. Pull out the cartridge using the lifting ring on top of the cartridge.

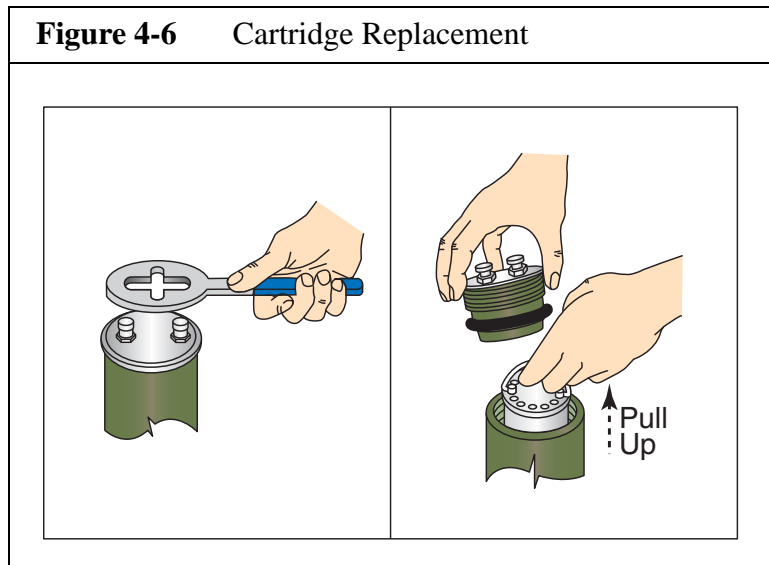

4. Dry the inside of the chamber with a clean cloth and check for corrosion.
5. Replace all corroded parts with new BAUER parts.
6. Remove the shipping covering and the protective cap from the bottom of the cartridge.
7. Lubricate the O-rings with white petroleum jelly. Apply sparingly.
8. Install the new cartridge. Be sure the cartridge snaps into place.
9. Reinstall the chamber head.
10. Close the bleed valve, restore the power and reconnect the inlet supply line, if applicable.

### NOTICE

If air is detected bleeding out from the bottom of the chamber, the cartridge has not been installed properly or is missing. Follow the instructions in Paragraph 4.4.2.1

#### 4.4.2.1 Leaking at the Safety Bore

1. Remove the cartridge following steps 1 to 3. in Paragraph 4.4.2.
2. Install cartridge if missing.
3. Remove cartridge and inspect O-rings.
4. Replace O-rings if necessary.
5. Ensure protective caps and devices have all been removed.
6. Replace cartridge following steps 7. to 10. in Paragraph 4.4.2

**4.5 Purification Cartridge Applicability**

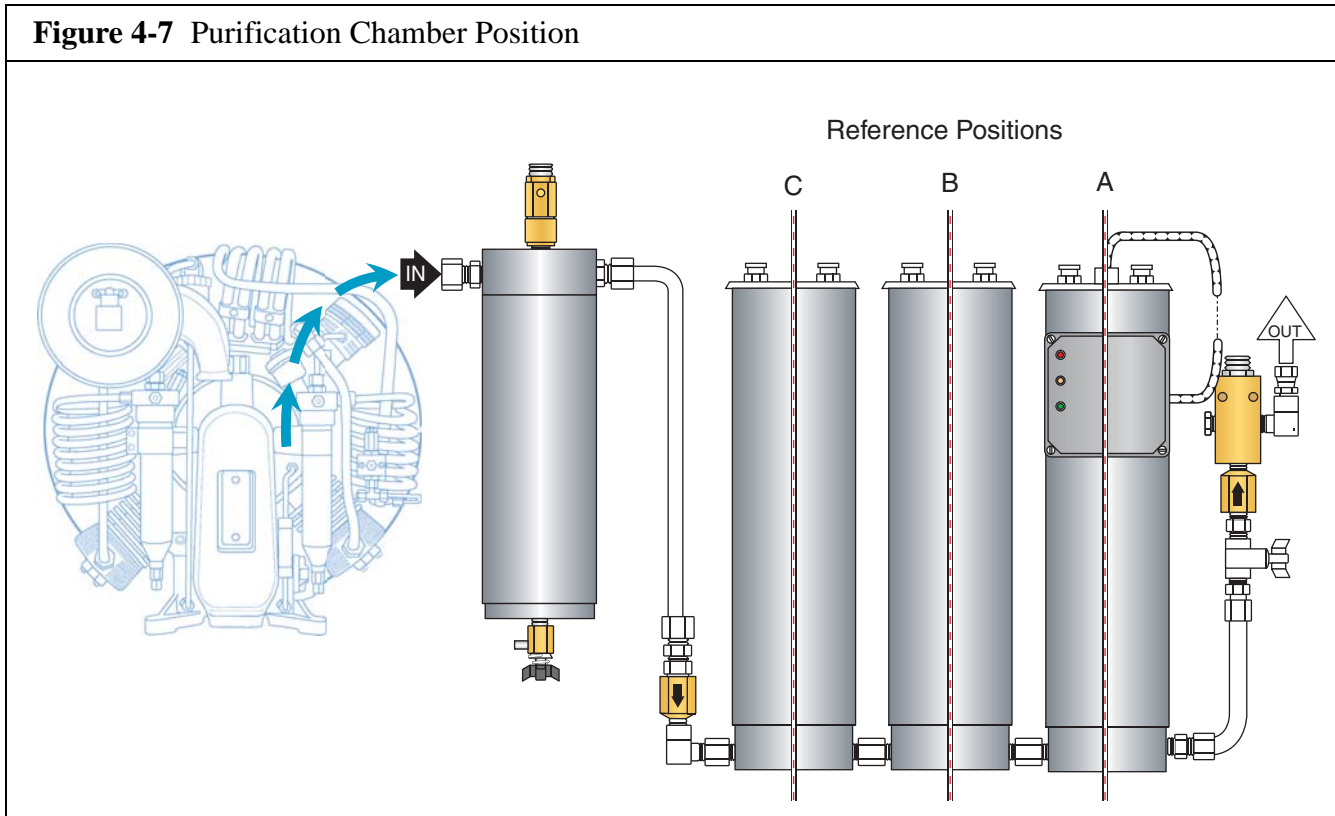

**4.5.1 Purification Chamber Position References**

The key to determining the reference location of the chamber and its corresponding cartridge is shown in Figure 4-7. The location begins with A closest to the System Output and works back toward the Compressor Input with as many letters as required. The Oil and Water Separator is not designated but is always closest to the Input. In Table 4-1 through Table 4-4 the Cartridge Part Numbers are cross-indexed to the Purification System Model Number and the highlighted Chamber Part Number. The Cartridge Part Numbers are used with Figure 4-24 through Figure 4-30 for determining the correct part numbers for maintenance and repair.

**Table 4-1: Cartridge Applications for Purification Systems: P1 to P4**

P/N	Description	P1	P2	P2S	IP2S	P4
080143	10" Chamber	A				A
080144	27" Chamber		A			B
080145	27" Securus Chamber			A	A	
058821A	10" Purification Cartridge, Breathing	A				A
058825A	27" Dryer Cartridge					B
058827A	27" Purification Cartridge, Breathing		A			
060037A	27" Securus Cartridge, Breathing			A	A	

P/N	Description	P5	P5S	IP5S	P10	P10S	IP10S
080144	27" Chamber	A,B	B	B	A,B,C	B,C	B,C
080145	27" Securus Chamber		A	A		A	A
058825A	27" Dryer Cartridge	B	B	B	B,C	B,C	B,C
060035	27" Securus Cartridge, Industrial			A			A
058827A	27" Purification Cartridge, Breathing	A			A		
060037A	27" Securus Cartridge, Breathing		A			A	

P/N	Description	P41	P41S	P42	P42S	P43	P43S
082135	20" Chamber	A	A	A,B	A	A,B,C	A,B
082136	20" Securus Chamber				B		C
062504	20" Dryer Cartridge			B	B	B,C	B,C
067224	20" Purification Cartridge, Breathing	A		A		A	
061687	20" Securus Cartridge, Breathing		A		A		A

P/N	Description	IP41	IP41S	IP42	IP42S	IP43	IP43S
082135	20" Chamber	A	A	A,B	A	A,B,C	A,B
082136	20" Securus Chamber				B		C
062504	20" Dryer Cartridge			B	B	B,C	B,C
061686	20" Securus Cartridge, Industrial		A		A		A
062565	20" Purification Cartridge, Industrial	A		A		A	

**4.6 Purification System Replacement Parts List**

**4.6.1 P1 Purification System**

**Figure 4-8** P1 Purification System

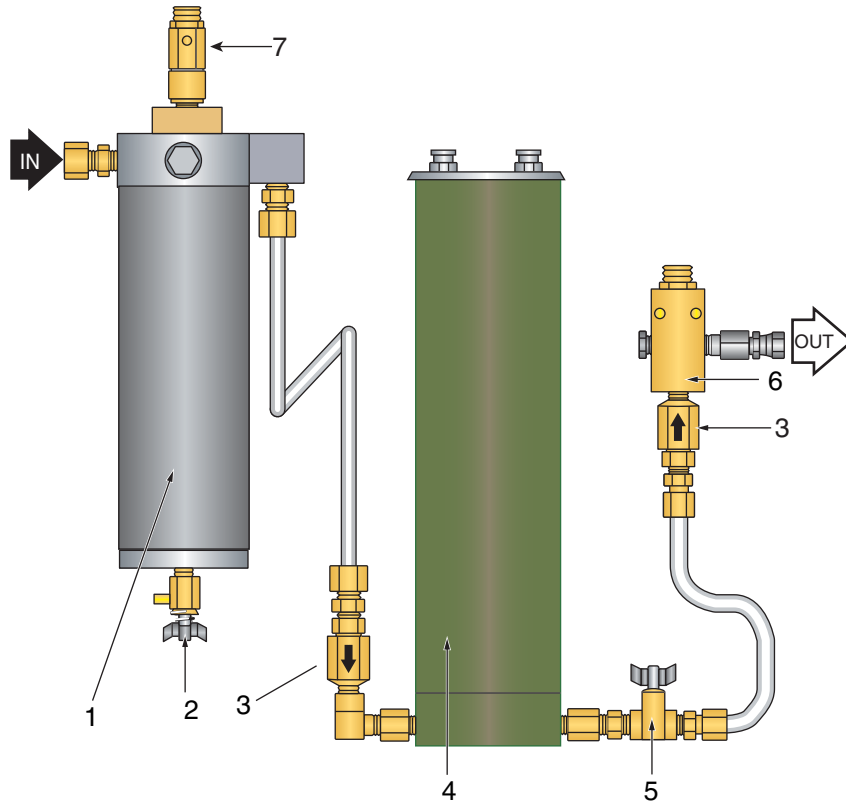

Item	Qty	Part No.	Description	Notes
1	1	079416	Oil and Water Separator	See Figure 4-23
2	1	011430	Condensate Drain Valve	
3	2	VAL-0007	Check Valves	
4	1	080143	10" Purification Chamber	See Figure 4-24
5	1	VAL-0377	Bleed Valve	
6	1	VAL-0053	Pressure Maintaining Valve	
7	1	VAL-0169	Safety Valve	

4.6.2 P2 Purification System

Figure 4-9 P2 Purification System

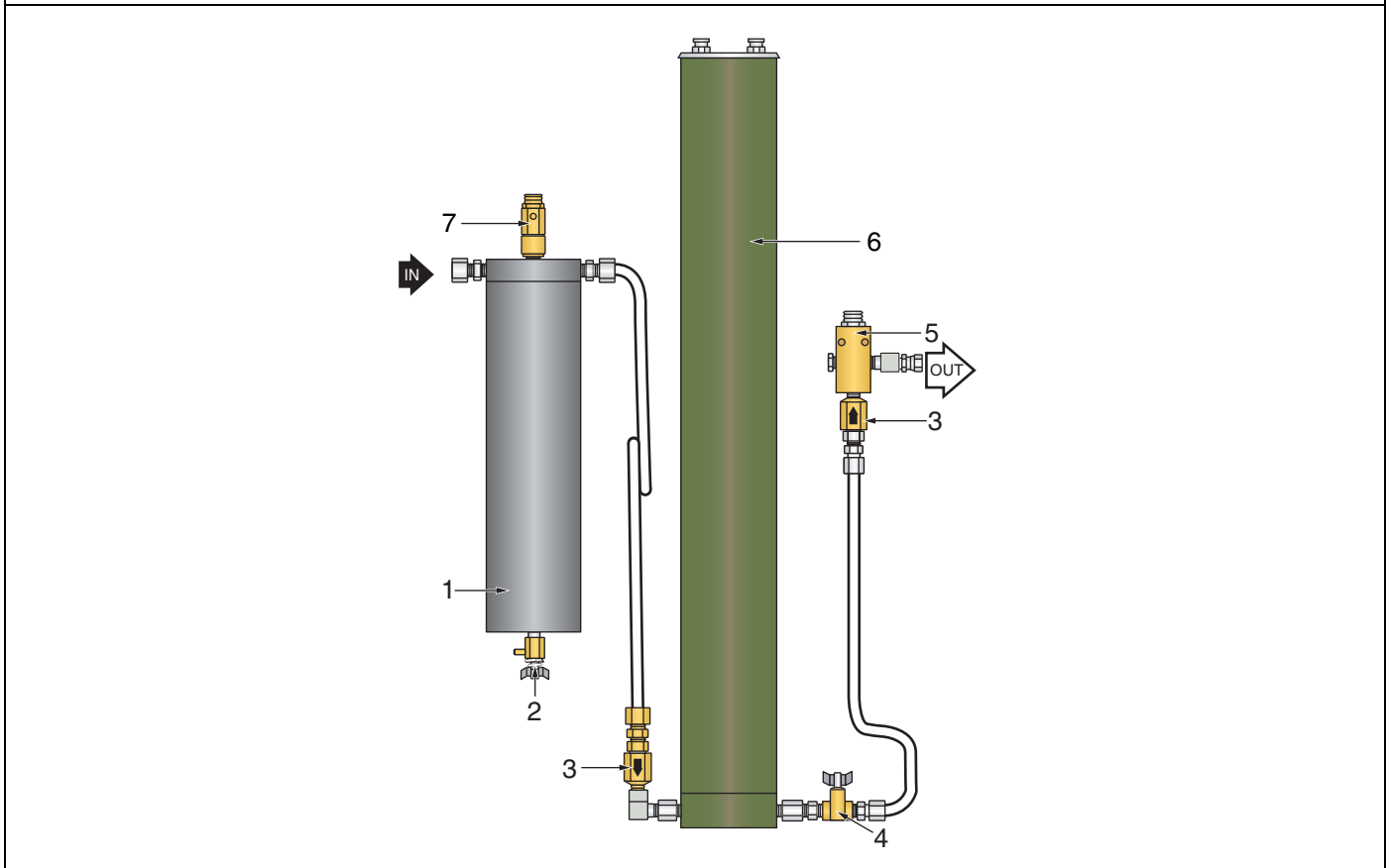

Item	Qty	Part No.	Description	Notes
1	1	079416	Oil and Water Separator	See Figure 4-23
2	1	011430	Condensate Drain Valve	
3	2	VAL-0007	Check Valves	
4	1	VAL-0377	Bleed Valve	
5	1	VAL-0053	Pressure Maintaining Valve	
6	1	080144	27" Purification Chamber	See Figure 4-28
7	1	VAL-0169	Safety Valve	

4.6.3 P2S and IP2S Purification System

Figure 4-10 P2S and IP2S Purification System

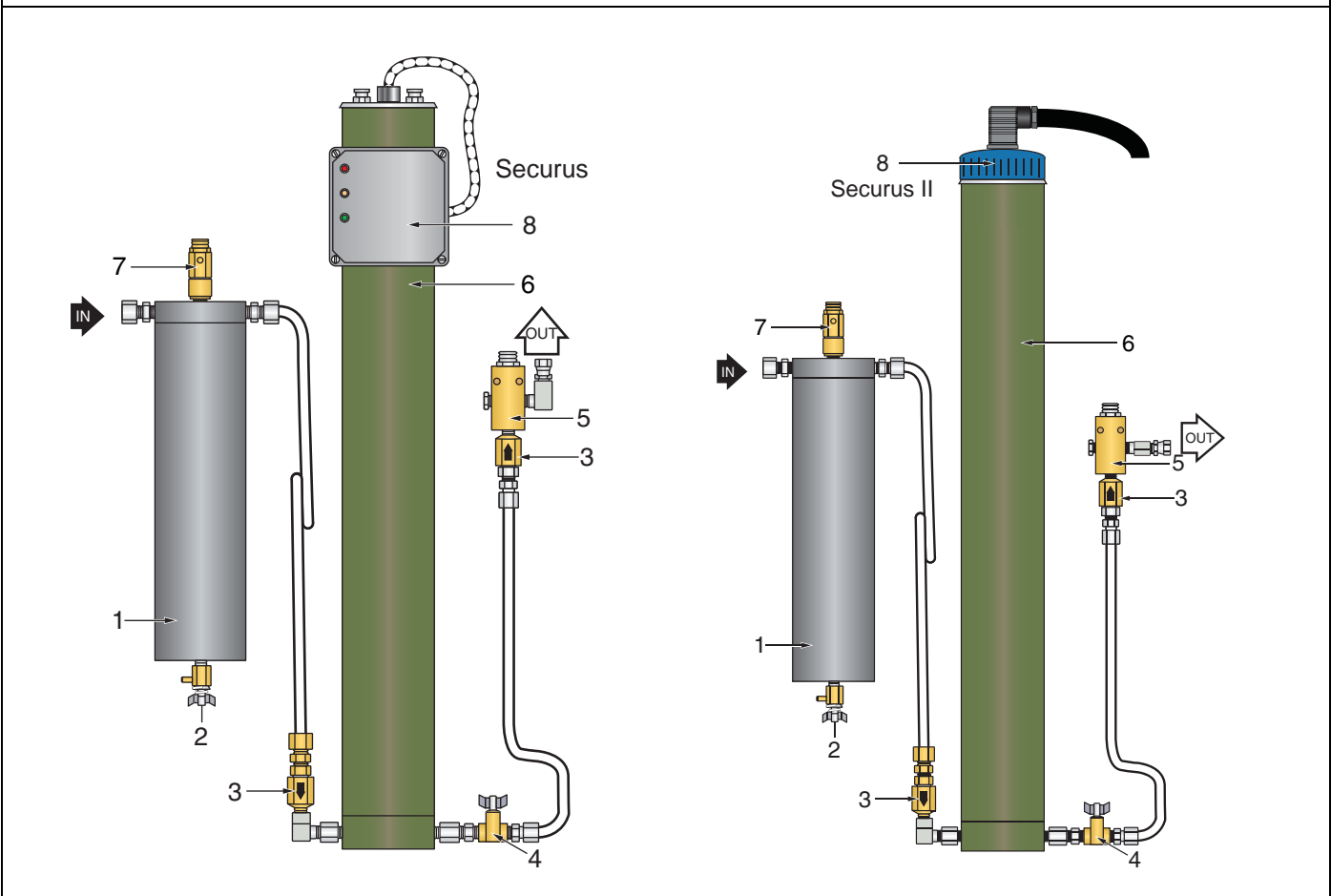

Item	Qty	Part No.	Description	Notes
1	1	079416	Oil and Water Separator	See Figure 4-23
2	1	011430	Condensate Drain Valve	
3	2	VAL-0007	Check Valves	
4	1	VAL-0377	Bleed Valve	
5	1	VAL-0053	Pressure Maintaining Valve	
6	1	080145	27"Securus® Purification Chamber	See Figure 4-30
7	1	VAL-0169	Safety Valve	
8	1	N15095	Securus® Indicator	110-120VAC, 50-60 Hz
—	1	N15096	Securus® Indicator	12-24 VDC
—	1	MNR-0042	Securus II® Monitor	



4.6.4 P4 Purification System

Figure 4-11 P4 Purification System

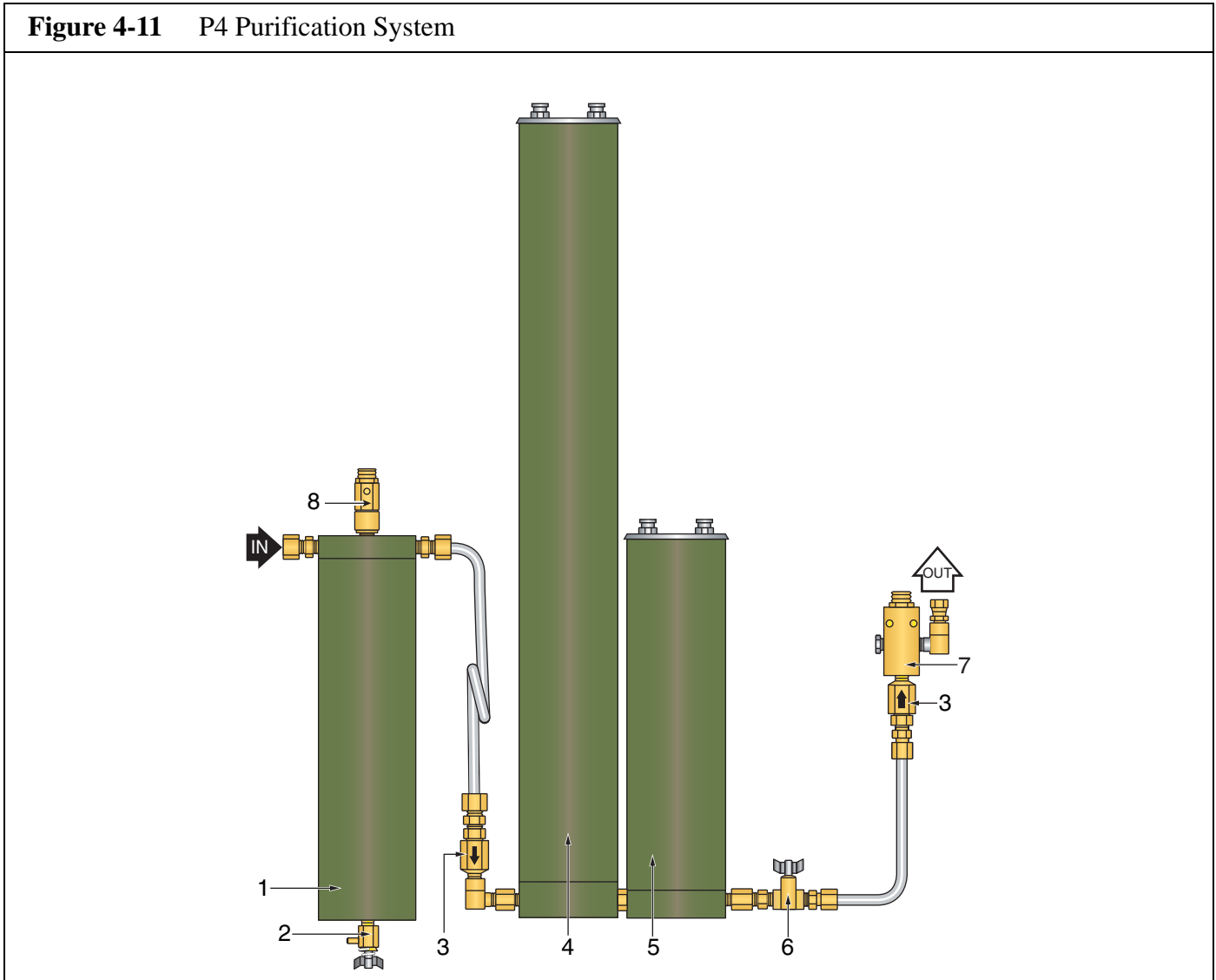

Item	Qty	Part No.	Description	Notes
1	1	079416	Oil and Water Separator	See Figure 4-23
2	1	011430	Condensate Drain Valve	
3	2	VAL-0007	Check Valves	
4	1	080144	27" Dryer Chamber	See Figure 4-28
5	1	080143	10" Purification Chamber	See Figure 4-24
6	1	VAL-0377	Bleed Valve	
7	1	VAL-0053	Pressure Maintaining Valve	
8	1	VAL-0169	Safety Valve	

4.6.5 P5 Purification System

Figure 4-12 P5 Purification System

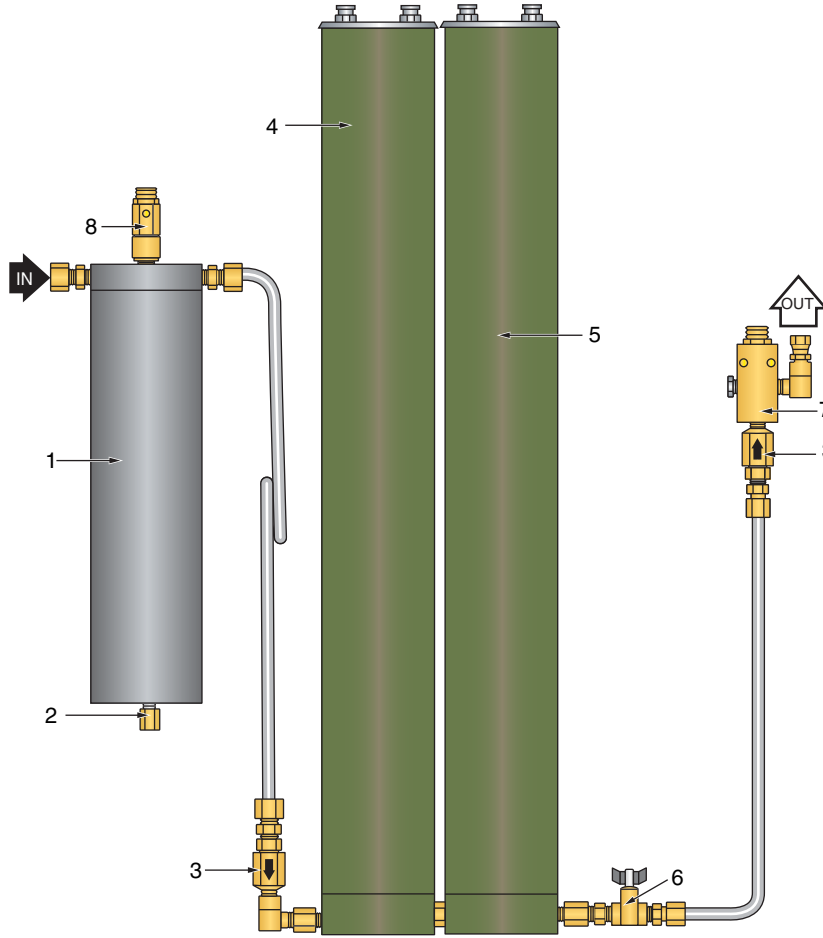

Item	Qty	Part No.	Description	Notes
1	1	079416	Oil and Water Separator	See Figure 4-23
2	1	011430	Condensate Drain Valve	
3	2	VAL-0007	Check Valves	
4	1	080144	27" Dryer Chamber	See Figure 4-28
5	1	080144	27" Purification Chamber	See Figure 4-28
6	1	VAL-0377	Bleed Valve	
7	1	VAL-0053	Pressure Maintaining Valve	
8	1	VAL-0169	Safety Valve	

4.6.6 P5S and IP5S Purification System

Figure 4-13 P5S and IP5S Purification System

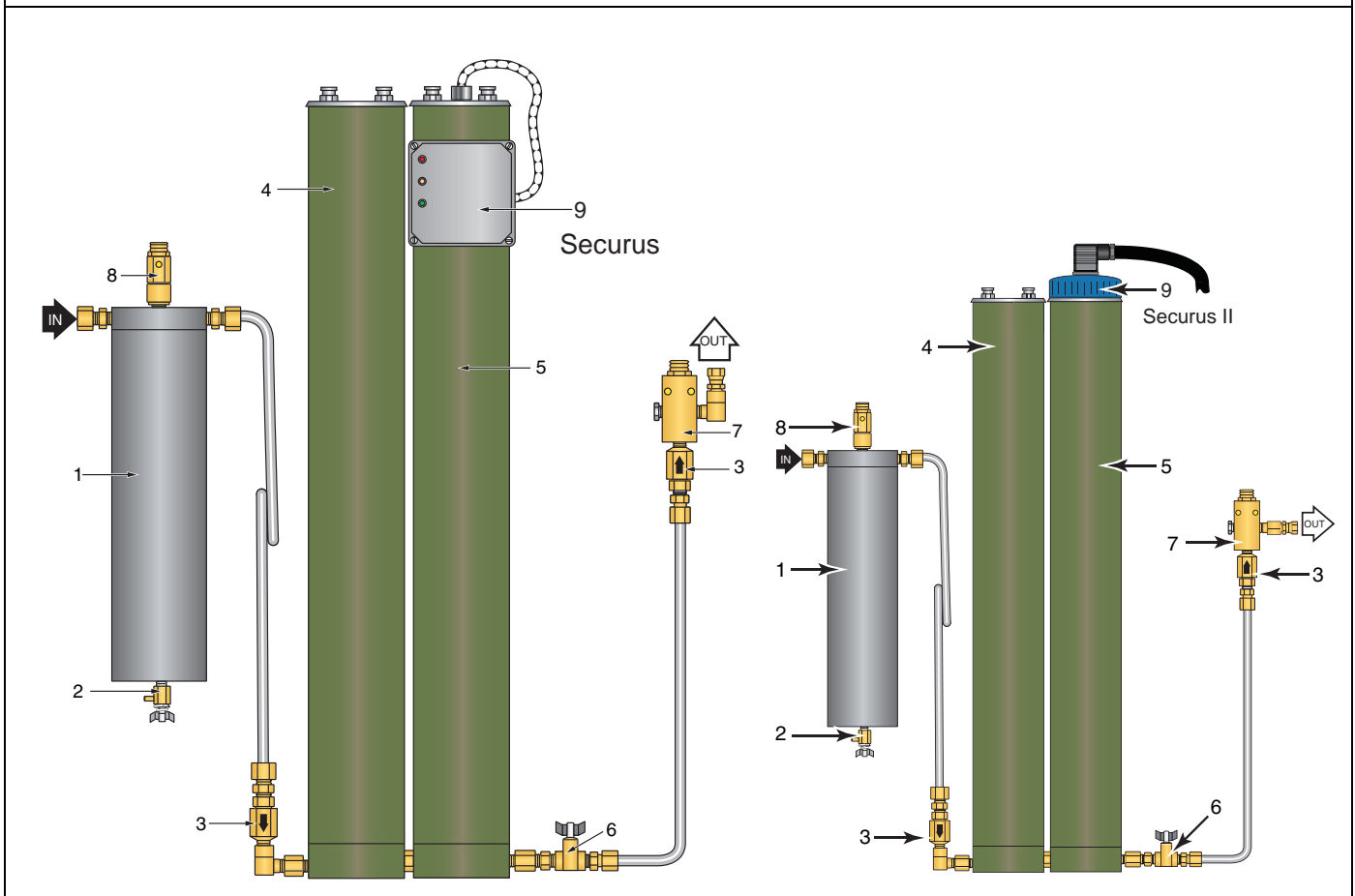

Item	Qty	Part No.	Description	Notes
1	1	079416	Oil and Water Separator	See Figure 4-23
2	1	011430	Condensate Drain Valve	
3	2	VAL-0007	Check Valves	
4	1	080144	27" Dryer Chamber	See Figure 4-28
5	1	080145	27" Securus® Chamber	See Figure 4-30
6	1	VAL-0377	Bleed Valve	
7	1	VAL-0053	Pressure Maintaining Valve	
8	1	VAL-0169	Safety Valve	
9	1	N15095	Securus® Indicator	110-120VAC, 50-60 Hz
—	1	N15096	Securus® Indicator	12-24 VDC
—	1	MNR-0042	Securus® Monitor	

4.6.7 P10 Purification System

Figure 4-14 P10 Purification System

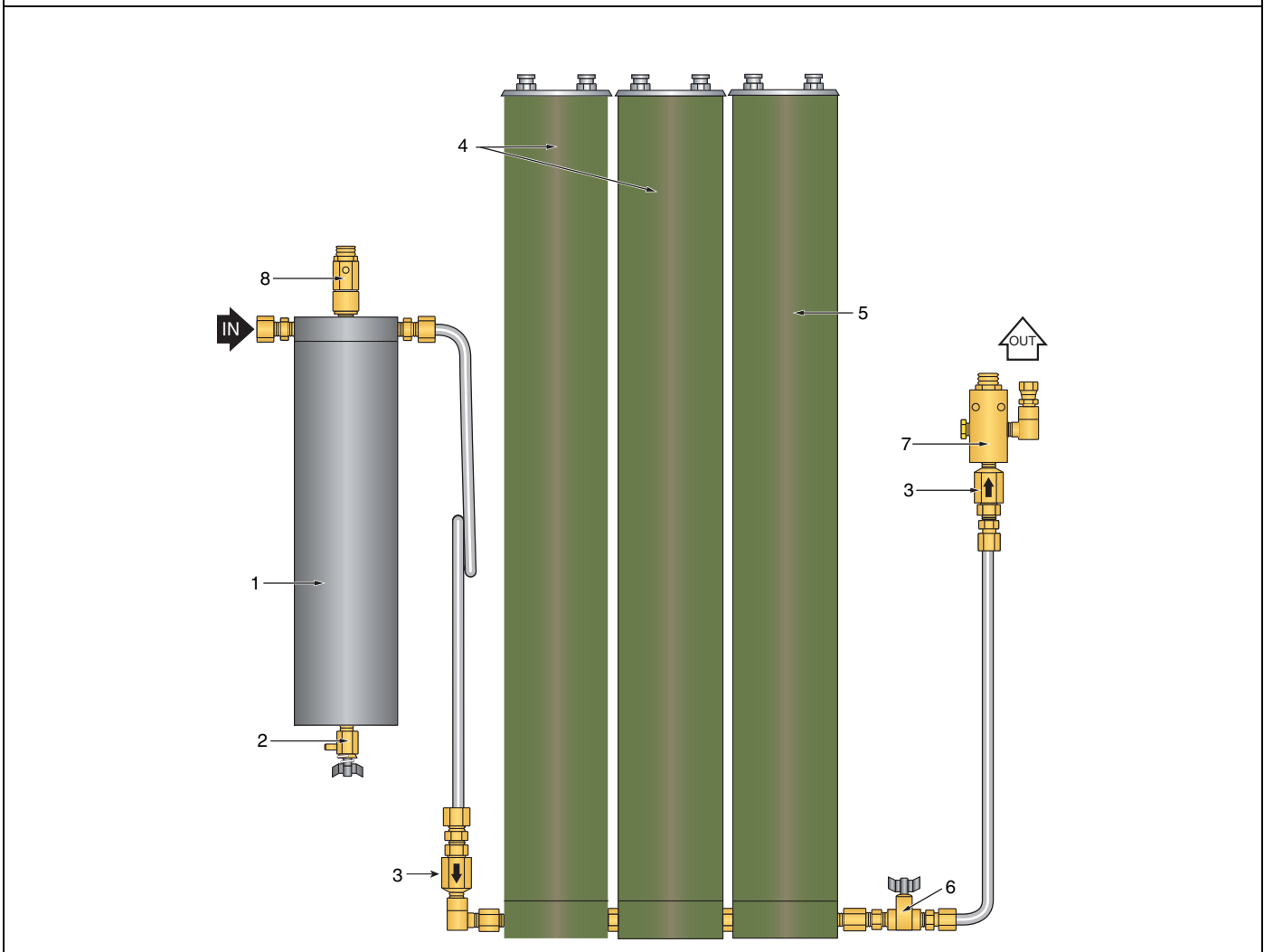

Item	Qty	Part No.	Description	Notes
1	1	079416	Oil and Water Separator	See Figure 4-23
2	1	011430	Condensate Drain Valve	
3	2	VAL-0007	Check Valves	
4	2	080144	27" Dryer Chamber	See Figure 4-28
5	1	080144	27" Purification Chamber	See Figure 4-28
6	1	VAL-0377	Bleed Valve	
7	1	VAL-0053	Pressure Maintaining Valve	
8	1	VAL-0169	Safety Valve	

4.6.8 P10S and IP10S Purification System

Figure 4-15 P10S and IP10S Purification System

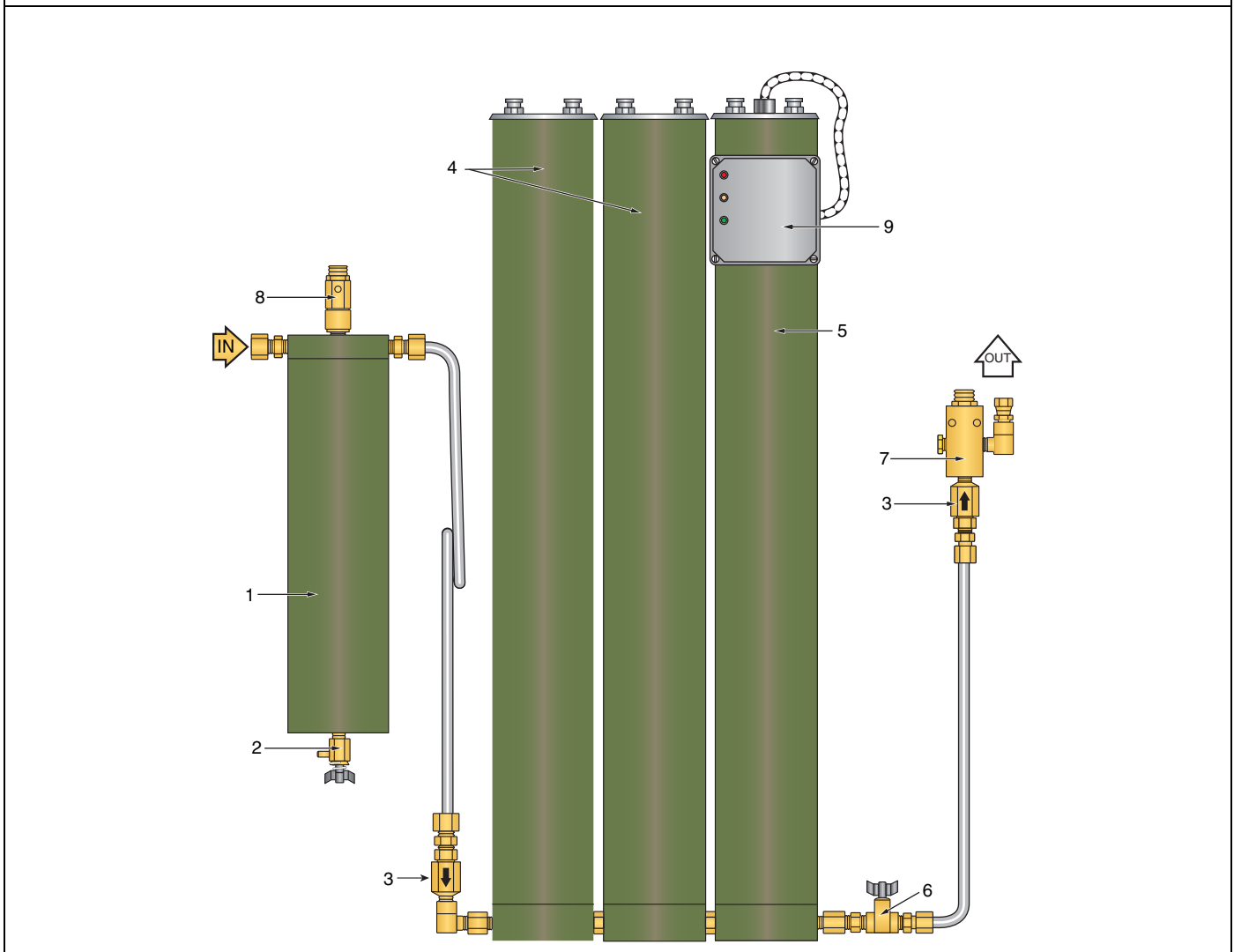

Item	Qty	Part No.	Description	Notes
1	1	079416	Oil and Water Separator	See Figure 4-23
2	1	011430	Condensate Drain Valve	
3	2	VAL-0007	Check Valves	
4	2	080144	27" Dryer Chamber	See Figure 4-28
5	1	080145	27" Securus® Chamber	See Figure 4-30
6	1	VAL-0377	Bleed Valve	
7	1	VAL-0053	Pressure Maintaining Valve	
8	1	VAL-0169	Safety Valve	
9	1	N15095	Securus® Indicator	110-120VAC, 50-60 Hz
—	1	N15096	Securus® Indicator	12-24 VDC

4.6.9 P10S II Purification System

Figure 4-16 P10S II Purification System

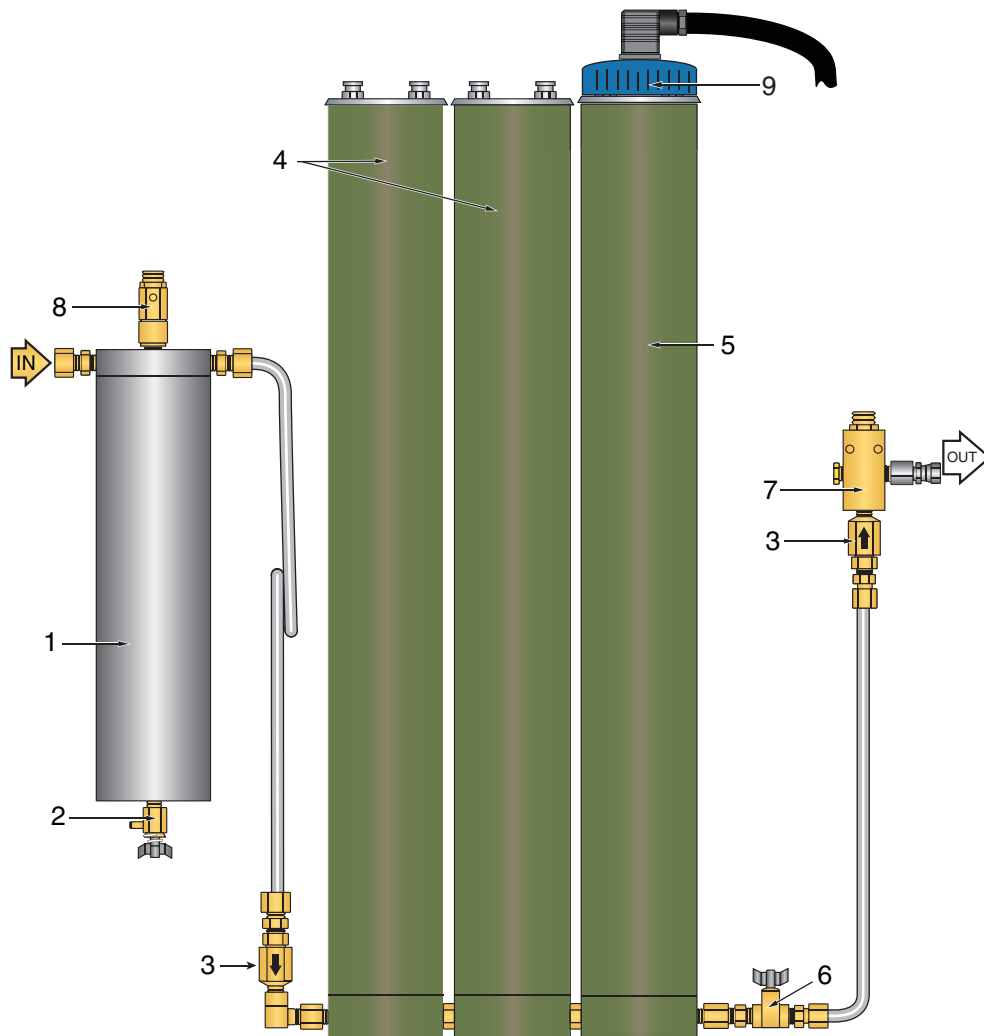

Item	Qty	Part No.	Description	Notes
1	1	079416	Oil and Water Separator	See Figure 4-23
2	1	011430	Condensate Drain Valve	
3	2	VAL-0007	Check Valves	
4	2	080144	27" Dryer Chamber	See Figure 4-28
5	1	080145	27" Securus® Chamber	See Figure 4-30
6	1	VAL-0377	Bleed Valve	
7	1	VAL-0053	Pressure Maintaining Valve	
8	1	VAL-0169	Safety Valve	
9	1	MNR-0042	Securus II® Monitor	

4.6.10 P41 and IP41 Purification System

Figure 4-17 P41 and IP41 Purification System

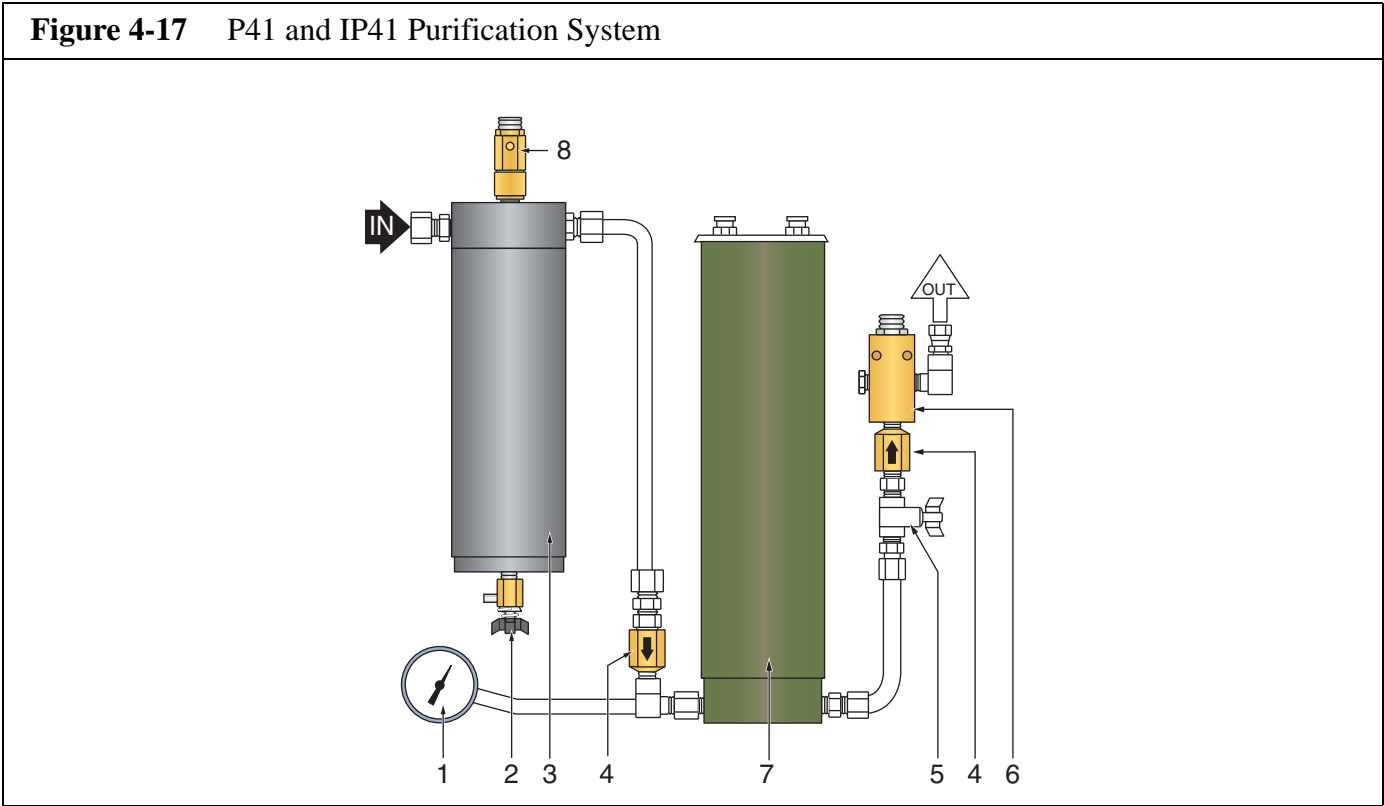

Item	Qty	Part No.	Description	Notes
1	1	GAG-0009W	Pressure Gauge	
2	1	011430	Condensate Drain Valve	
3	1	079416	Oil and Water Separator	See Figure 4-23
4	1	VAL-0007	Check Valves	
5	1	VAL-0377	Bleed Valve	
6	1	VAL-0053	Pressure Maintaining Valve	
7	1	082135	20" Purification Chamber	See Figure 4-25
8	1	VAL-0169	Safety Valve	

4.6.11 P41S and IP41S Purification System

Figure 4-18 P41S and IP41S Purification System

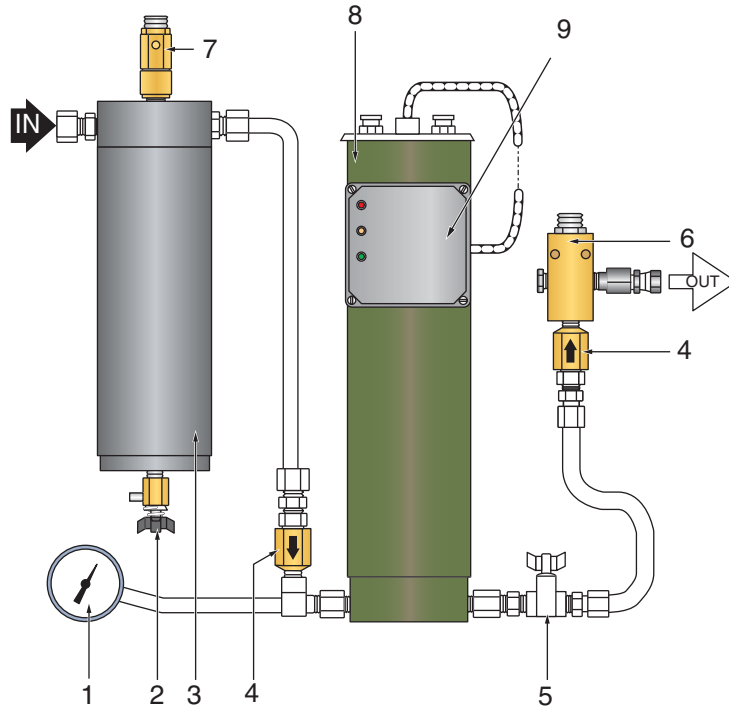

Item	Qty	Part No.	Description	Notes
1	1	GAG-0009W	Pressure Gauge	
2	1	011430	Condensate Drain Valve	
3	1	079416	Oil and Water Separator	See Figure 4-23
4	1	VAL-0007	Check Valves	
5	1	VAL-0377	Bleed Valve	
6	1	VAL-0053	Pressure Maintaining Valve	
7	1	VAL-0169	Safety Valve	
8	1	082136	20" Securus® Purification Chamber	See Figure 4-26
9	1	N15095	Securus® Indicator	110-120VAC, 50-60 Hz
—	1	N15096	Securus® Indicator	12-24 VDC



4.6.12 P42 and IP42 Purification System

Figure 4-19 P42 and IP42 Purification System

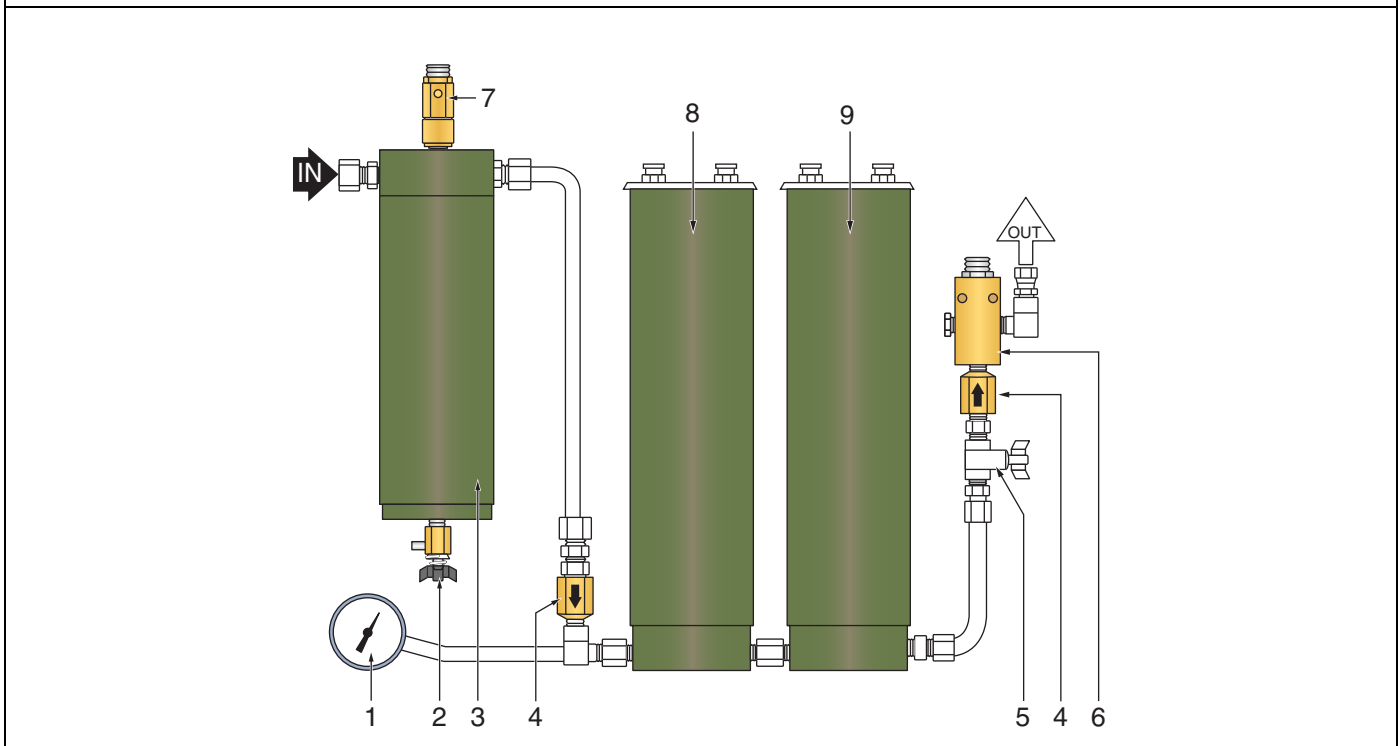

Item	Qty	Part No.	Description	Notes
1	1	GAG-0009W	Pressure Gauge	
2	1	011430	Condensate Drain Valve	
3	1	079416	Oil and Water Separator	See Figure 4-23
4	1	VAL-0007	Check Valves	
5	1	VAL-0377	Bleed Valve	
6	1	VAL-0053	Pressure Maintaining Valve	
7	1	VAL-0169	Safety Valve	
8	1	082135	20" Dryer Chamber	See Figure 4-25
9	1	082135	20" Purification Chamber	See Figure 4-25

4.6.13 P42S and IP42S Purification System

Figure 4-20 P42S and IP42S Purification System

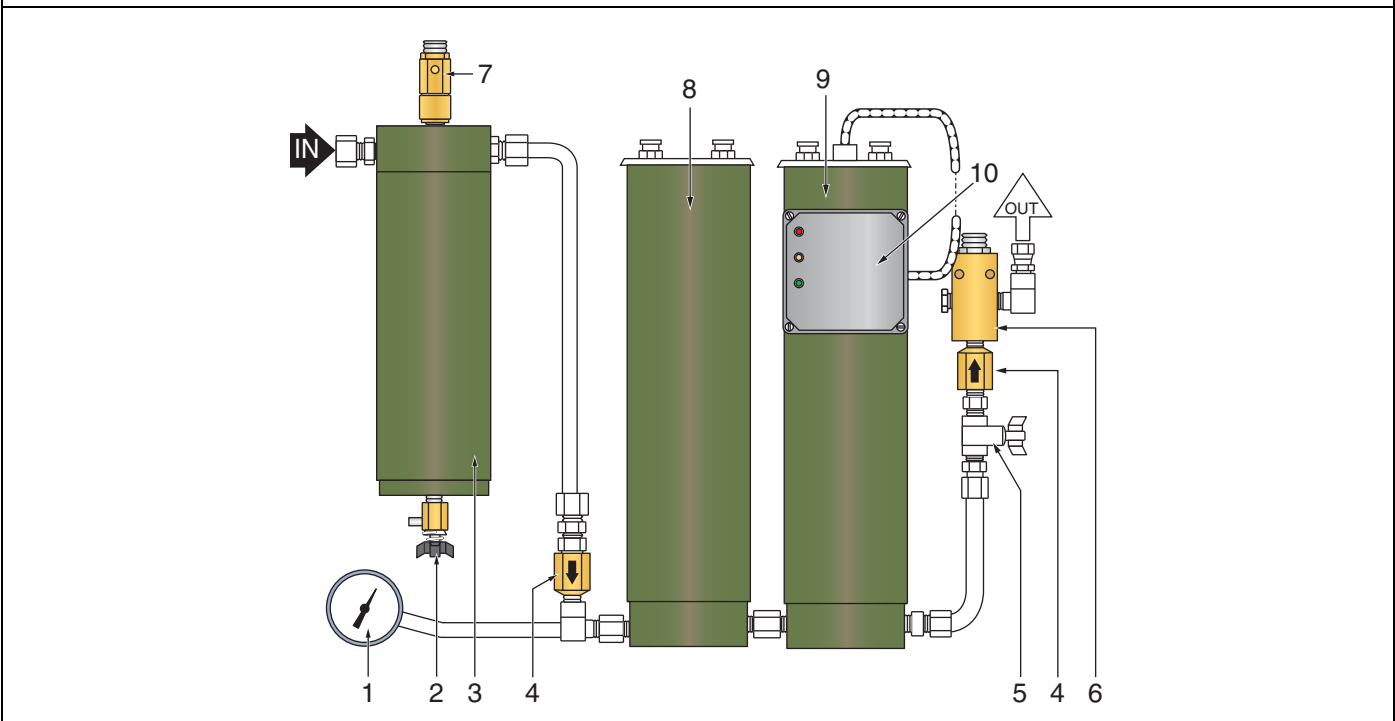

Item	Qty	Part No.	Description	Notes
1	1	GAG-0009W	Pressure Gauge	
2	1	011430	Condensate Drain Valve	
3	1	079416	Oil and Water Separator	See Figure 4-23
4	1	VAL-0007	Check Valves	
5	1	VAL-0377	Bleed Valve	
6	1	VAL-0053	Pressure Maintaining Valve	
7	1	VAL-0169	Safety Valve	
8	1	082135	20" Dryer Chamber	See Figure 4-25
9	1	082136	20" Securus® Purification Chamber	See Figure 4-26
10	1	N15095	Securus® Indicator	110-120VAC, 50-60 Hz
—	1	N15096	Securus® Indicator	12-24 VDC

4.6.14 P43 and IP43 Purification System

Figure 4-21 P43 and IP43 Purification System

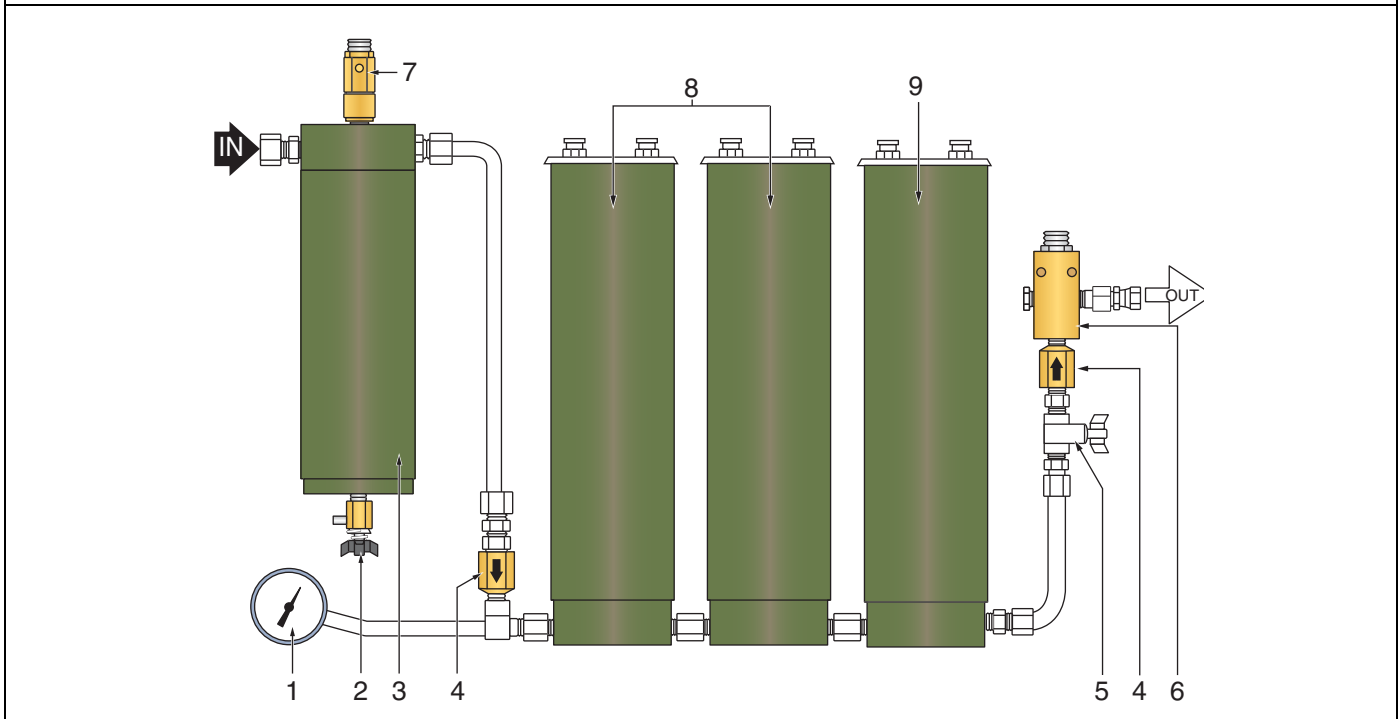

Item	Qty	Part No.	Description	Notes
1	1	GAG-0009W	Pressure Gauge	
2	1	011430	Condensate Drain Valve	
3	1	079416	Oil and Water Separator	See Figure 4-23
4	1	VAL-0007	Check Valves	
5	1	VAL-0377	Bleed Valve	
6	1	VAL-0053	Pressure Maintaining Valve	
7	1	VAL-0169	Safety Valve	
8	2	082135	20" Dryer Chamber	See Figure 4-25
9	1	082135	20" Purification Chamber	See Figure 4-25

4.6.15 P43S and IP43S Purification System

Figure 4-22 P43S and IP43S Purification System

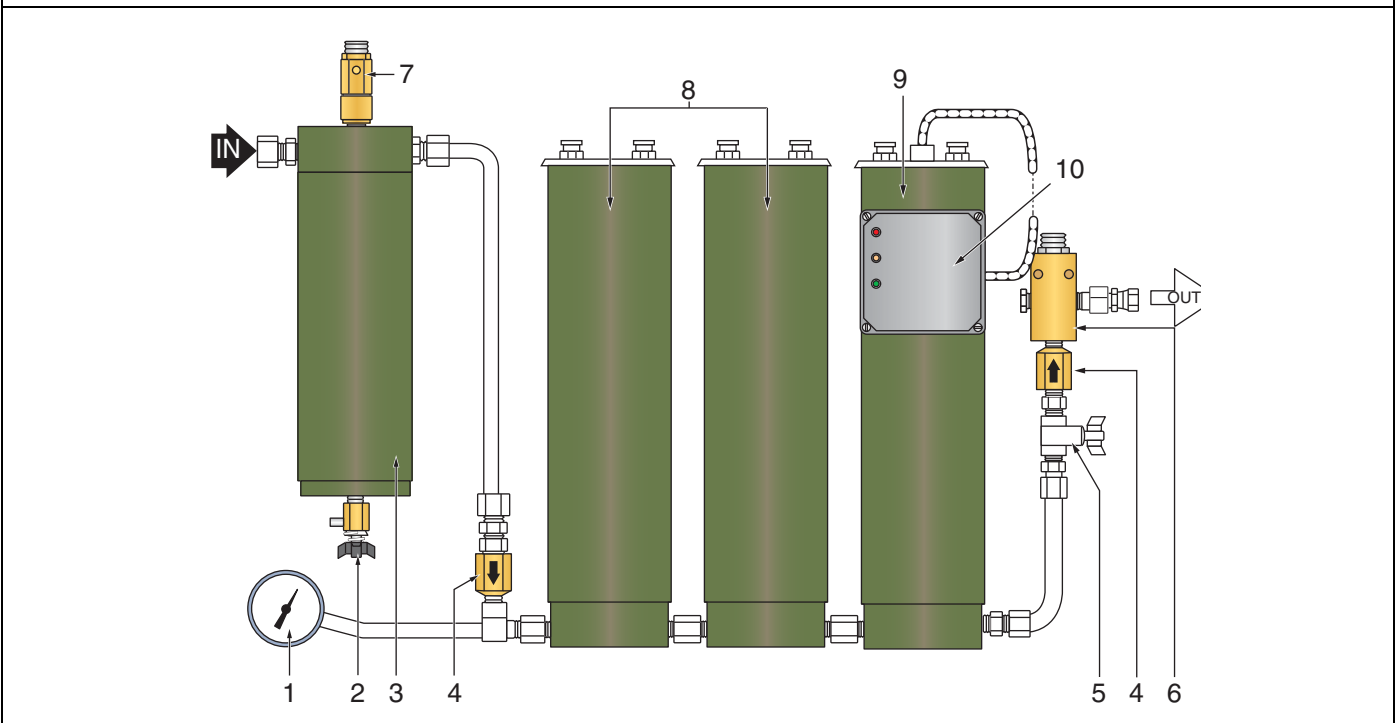

Item	Qty	Part No.	Description	Notes
1	1	GAG-0009W	Pressure Gauge	
2	1	011430	Condensate Drain Valve	
3	1	079416	Oil and Water Separator	See Figure 4-23
4	1	VAL-0007	Check Valves	
5	1	VAL-0377	Bleed Valve	
6	1	VAL-0053	Pressure Maintaining Valve	
7	1	VAL-0169	Safety Valve	
8	2	082135	20" Dryer Chamber	See Figure 4-25
9	1	082136	20" Securus® Purification Chamber	See Figure 4-26
10	1	N15095	Securus® Indicator	110-120VAC, 50-60 Hz
—	1	N15096	Securus® Indicator	12-24 VDC

4.7 Purification Components Replacement Parts List

4.7.1 Oil and Water Separator, P/N 079416

Figure 4-23 Oil and Water Separator, P/N 079416

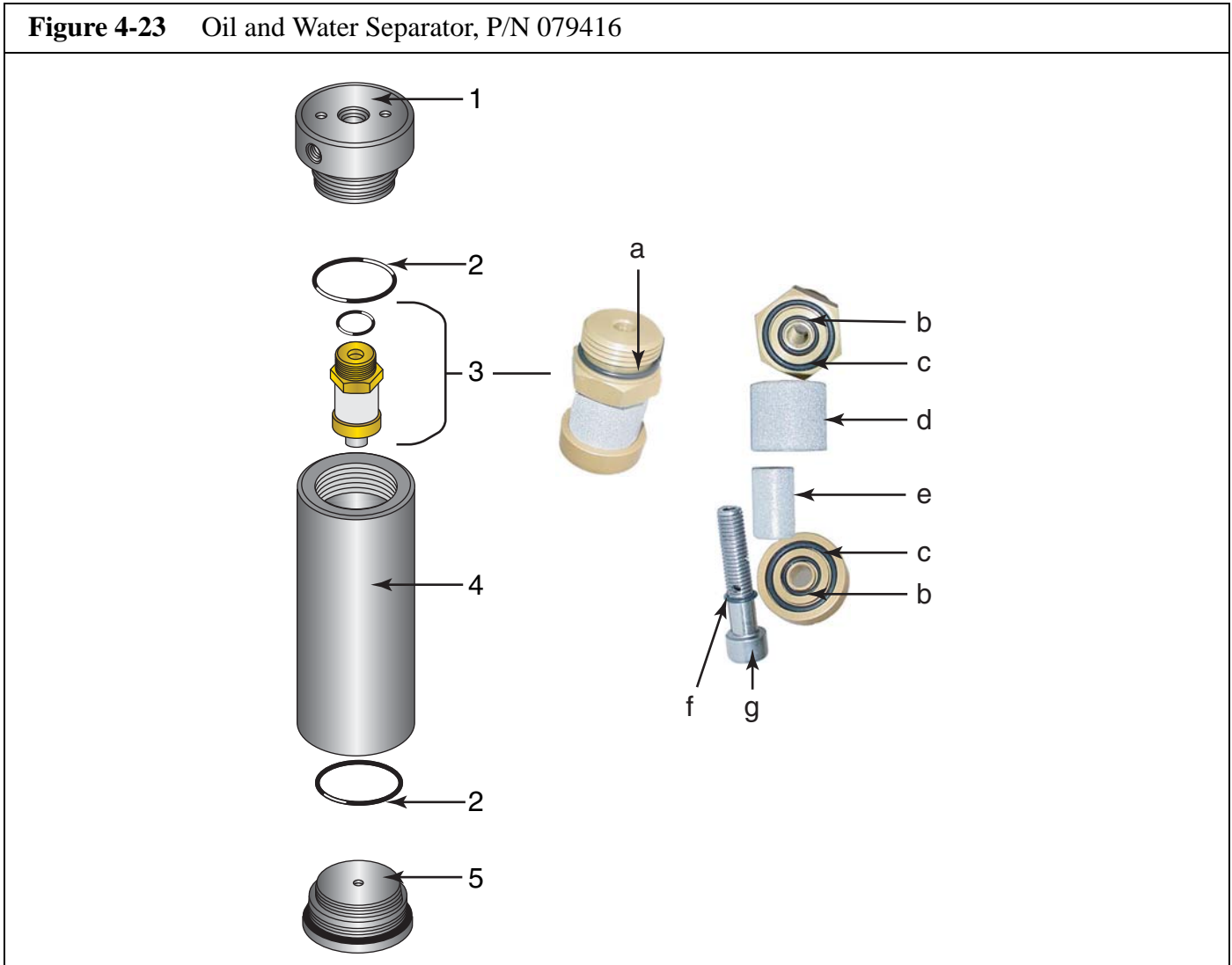

Item	Qty	Part No.	Description	Notes
◇	1	079416	Oil and Water Separator Assembly	
1	†	—	Separator Head	Available only with 079416
2	2	N04586	O-Ring	
3	1	061860	Sintered Metal Filter	
3a	1	N15133	O-Ring	
3b	2	N04496	O-Ring, small	
3c	2	N04385	O-Ring, large	
3d	1	061858	Sleeve Element, large	
3e	1	061859	Sleeve Element, small	
3f	1	N07091	O-Ring	
3g	1	061857	Screw	
4	†	—	Separator Housing	Available only with 079416
5	†	—	Bottom Plug	Available only with 079416

4.7.2 10" Chamber, P/N 080143

Figure 4-24 10" Chamber, P/N 080143

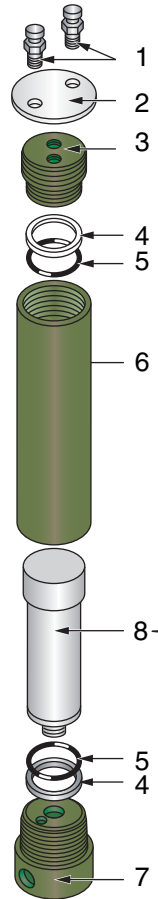

Item	Qty	Part No.	Description	Notes
◇	1	080143	Chamber Assembly	10"
1	2	012293	Tool Post Screw	
2	1	061237	Cover Plate	
3	†	...	Filter Head	Available only with 080143
4	2	N04736	Back-up Ring	
5	2	N04735	O-ring	
6	†	...	Filter Housing	Available only with 080143
7	†	...	Filter Bottom	Available only with 080143
8	1	*	10" Purification Cartridge	Refer to Paragraph 4.5

4.7.3 20” Chamber P/N 082135

Figure 4-25 20” Chamber P/N 082135

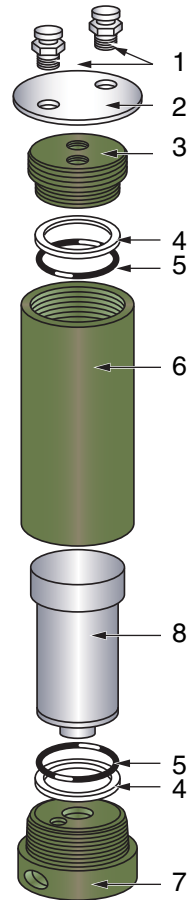

Item	Qty	Part No.	Description	Notes
◇	1	082135	20” Chamber Assembly	
1	2	012293	Tool Post Screw	
2	1	061237	Cover Plate	
3	†	...	Filter Head	Available only with 082135
4	2	N04736	Back-up Ring	
5	2	N04735	O-ring	
6	†	82137	Filter Housing	Available only with 082135
7	†	80148	Filter Bottom	Available only with 082135
8	1	*	Cartridge	Refer to Paragraph 4.5

4.7.4 20" Securus® Chamber P/N 082136

Figure 4-26 20" Securus® Chamber P/N 082136

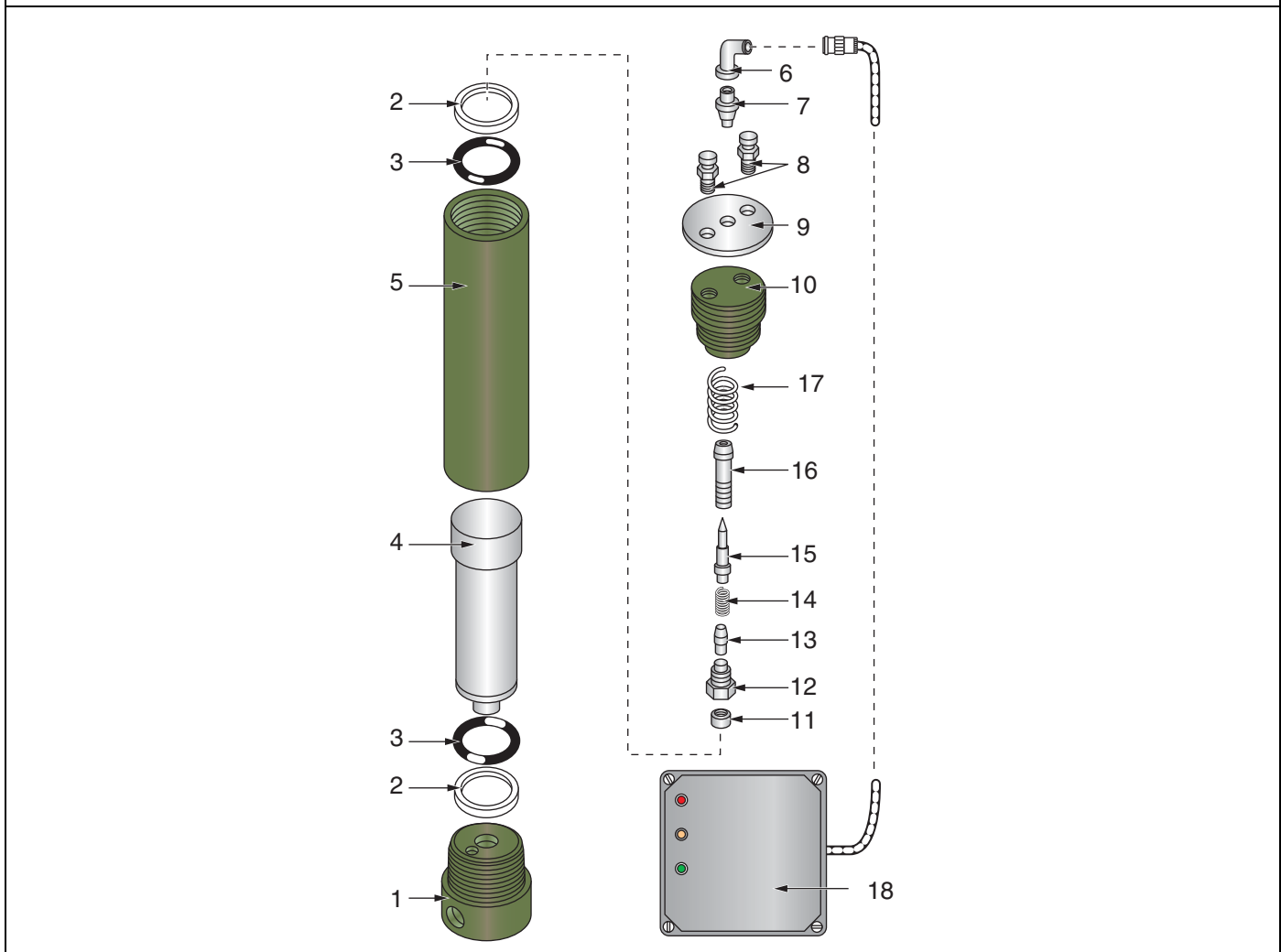

Item	Qty	Part No.	Description	Notes
◇	1	082136	Securus® Chamber Assembly	
1	†	...	Bottom Plug	Available only with 082136
2	2	N04736	Backup Ring	
3	2	N04735	O-ring	
4	1	*	Securus® Cartridge	Refer to Paragraph 4.5
5	†	...	Filter Body	Available only with 082136
6	1	ADP-0204	Adapter, Right Angle	
7	1	059850	Socket, RF type	
8	2	012293	Tool Post Screw	
9	1	06135	Cover Plate	
10	†	...	Filter Head	Available only with 082136



**Figure 4-26 (cont.)**

20" Securus® Chamber P/N 082136

<b>Item</b>	<b>Qty</b>	<b>Part No.</b>	<b>Description</b>	<b>Notes</b>
11	1	059855	Nut	
12	1	059852	Drawback Screw	
13	1	059854	Loose Pin	
14	1	060062	Compression Spring	
15	1	059853	Fixed Pin	
16	1	059851	Bolt	
17	1	002181	Compression Spring	
18	1	N15095	Securus® Indicator	110 - 120VAC, 50 - 60 Hz
—	1	N15096	Securus® Indicator	12 - 24 VDC

4.7.5 20" Securus II® Chamber P/N 082136

Figure 4-27 20" Securus® Chamber P/N 082136

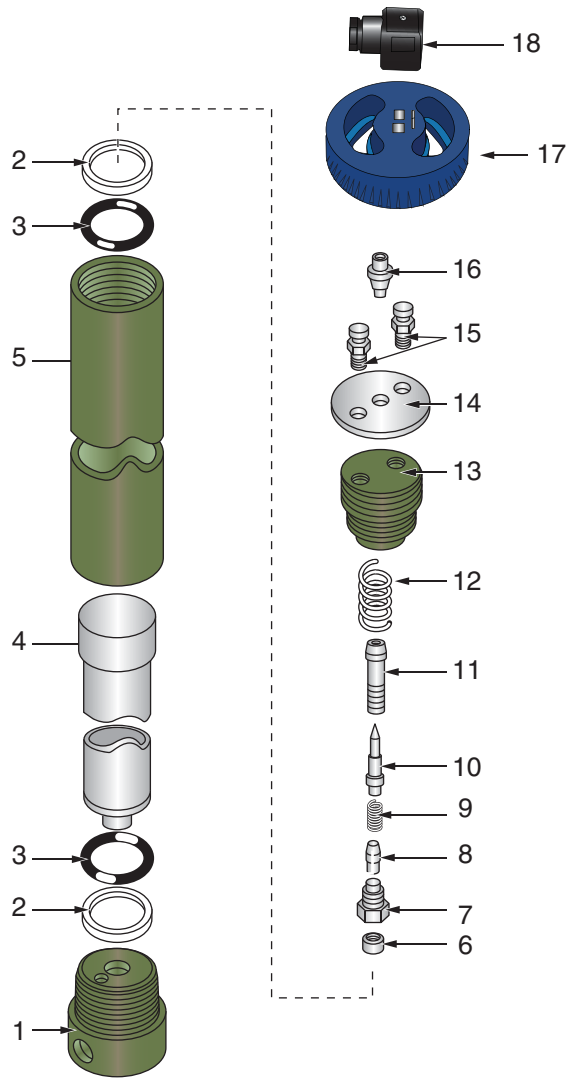

Item	Qty	Part No.	Description	Notes
◇	1	082136	Securus® Chamber Assembly	
1	†	...	Bottom Plug	Available only with 082136
2	2	N04736	Backup Ring	
3	2	N04735	O-ring	
4	1	*	Securus® Cartridge	Refer to Paragraph 4.5
5	†	...	Filter Body	Available only with 082136
6	1	059855	Nut	
7	1	059852	Drawback Screw	
8	1	059854	Loose Pin	
9	1	060062	Compression Spring	
10	1	059853	Fixed Pin	

**Figure 4-27 (cont.)**

20" Securus® Chamber P/N 082136

<b>Item</b>	<b>Qty</b>	<b>Part No.</b>	<b>Description</b>	<b>Notes</b>
11	1	059851	Bolt	
12	1	002181	Compression Spring	
13	†	...	Filter Head	Available only with 082136
14	1	06135	Cover Plate	
15	2	012293	Tool Post Screw	
16	1	059850	Socket, RF type	
17	1	MNR-0042	Securus II® Monitor	
18	1	CON-0319	Electrical Connector	

4.7.6 27" Chamber P/N 080144

Figure 4-28 27" Chamber P/N 080144

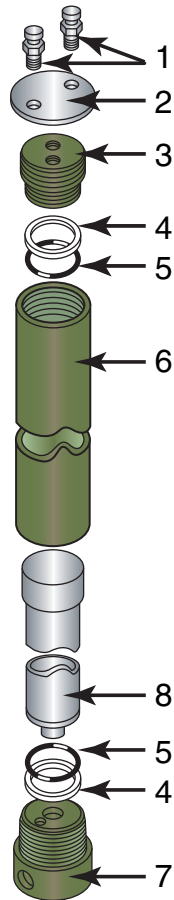

Item	Qty	Part No.	Description	Notes
◇	2	80144	Chamber Assembly	27"
1	2	012293	Tool Post Screw	
2	1	061237	Cover Plate	
3	†	...	Filter Head	Available only with 80144
4	2	N04736	Back-up Ring	
5	2	N04735	O-ring	
6	†	...	Filter Housing	Available only with 80144
7	†	...	Filter Bottom	Available only with 80144
8	1	*	Cartridge	Refer to Paragraph 4.5



4.7.7 27" Securus® Chamber P/N 080145

Figure 4-29 27" Securus® Chamber P/N 080145

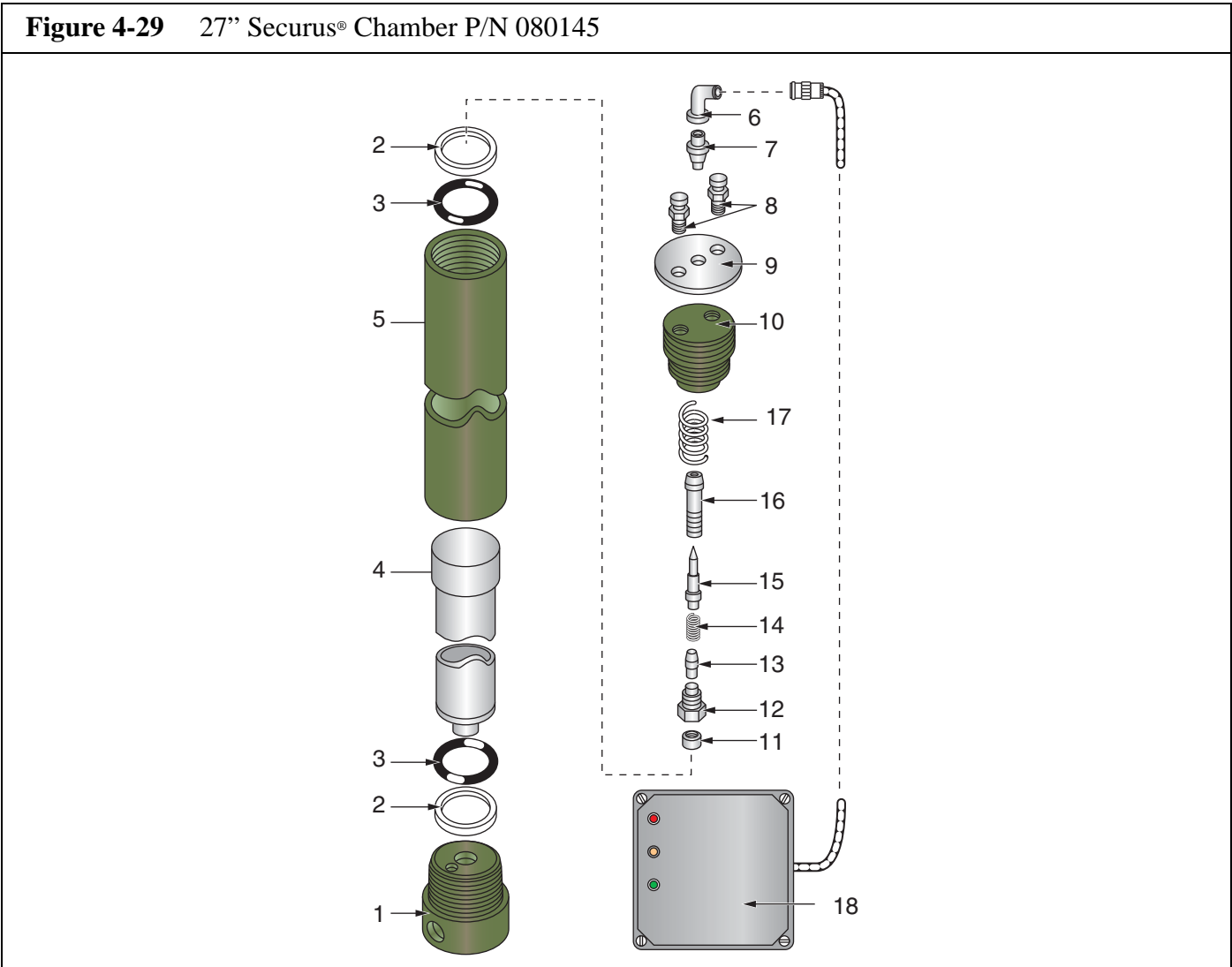

Item	Qty	Part No.	Description	Notes
◇	1	80145	Securus® Chamber Assembly	
1	†	...	Bottom Plug	Available only with 80145
2	2	N04736	Backup Ring	
3	2	N04735	O-ring	
4	1	*	Securus® Cartridge	Refer to Paragraph 4.5
5	†	...	Filter Body	Available only with 80145
6	1	ADP-0204	Adapter, Right Angle	
7	1	059850	Socket, RF type	
8	2	012293	Tool Post Screw	
9	1	06135	Cover Plate	
10	†	...	Filter Head	Available only with 80145
11	1	059855	Nut	

**Figure 4-29 (cont.)**

27" Securus® Chamber P/N 080145

<b>Item</b>	<b>Qty</b>	<b>Part No.</b>	<b>Description</b>	<b>Notes</b>
12	1	059852	Drawback Screw	
13	1	059854	Loose Pin	
14	1	060062	Compression Spring	
15	1	059853	Fixed Pin	
16	1	059851	Bolt	
17	1	002181	Compression Spring	
18	1	N15095	Securus® Indicator	110 - 120VAC, 50 - 60 Hz
—	1	N15096	Securus® Indicator	12 - 24 VDC

4.7.8 27" Securus II® Chamber P/N 080145

Figure 4-30 27" Securus II® Chamber P/N 080145

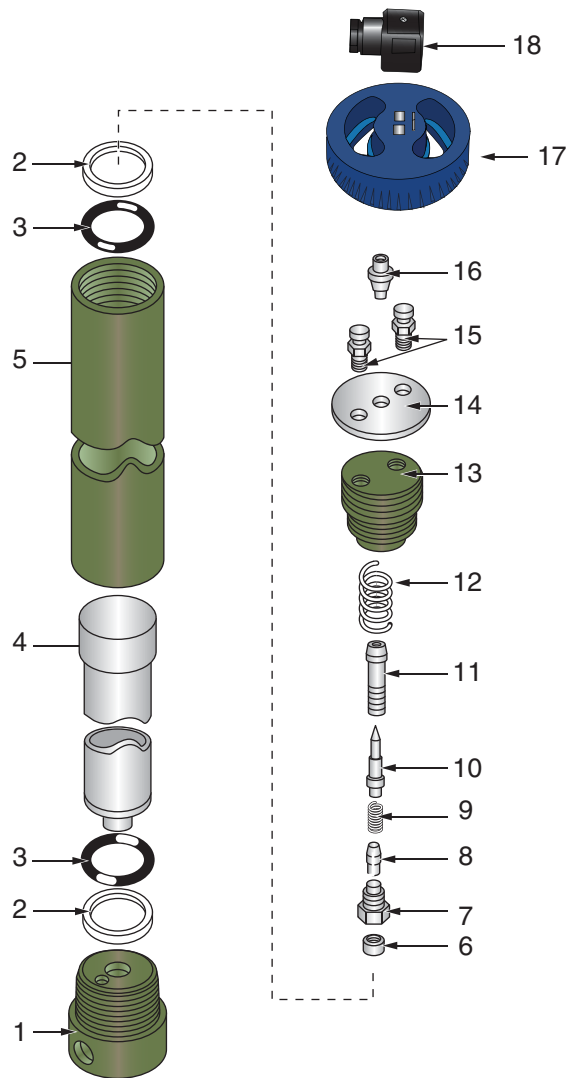

Item	Qty	Part No.	Description	Notes
◇	1	80145	Securus® Chamber Assembly	
1	†	...	Bottom Plug	Available only with 80145
2	2	N04736	Backup Ring	
3	2	N04735	O-ring	
4	1	*	Securus® Cartridge	Refer to Paragraph 4.5
5	†	...	Filter Body	Available only with 80145
6	1	059855	Nut	
7	1	059852	Drawback Screw	
8	1	059854	Loose Pin	
9	1	060062	Compression Spring	
10	1	059853	Fixed Pin	



**Figure 4-30 (cont.)**

27" Securus II® Chamber P/N 080145

<b>Item</b>	<b>Qty</b>	<b>Part No.</b>	<b>Description</b>	<b>Notes</b>
11	1	059851	Bolt	
12	1	002181	Compression Spring	
13	†	...	Filter Head	Available only with 80145
14	1	06135	Cover Plate	
15	2	012293	Tool Post Screw	
16	1	059850	Socket, RF type	
17	1	MNR-0042	Securus II® Monitor	
18	1	CON-0319	Electrical Connector	

**CHAPTER 5: HIGH FLOW PURIFICATION SYSTEMS**

**5.1 Applicability**

This chapter applies to these Bauer Purification System models: P12 and P14.

**5.2 P12 Purification System**

**5.2.1 Major Components and Configurations**

The P12 Purification System major components are an Oil and Water Separator, a Dryer Chamber and a Purification Chamber. Figure 5-1 shows the functional interconnection of all the components. The Securus® Electronic Moisture Monitor System is standard with the P12 Purification System.

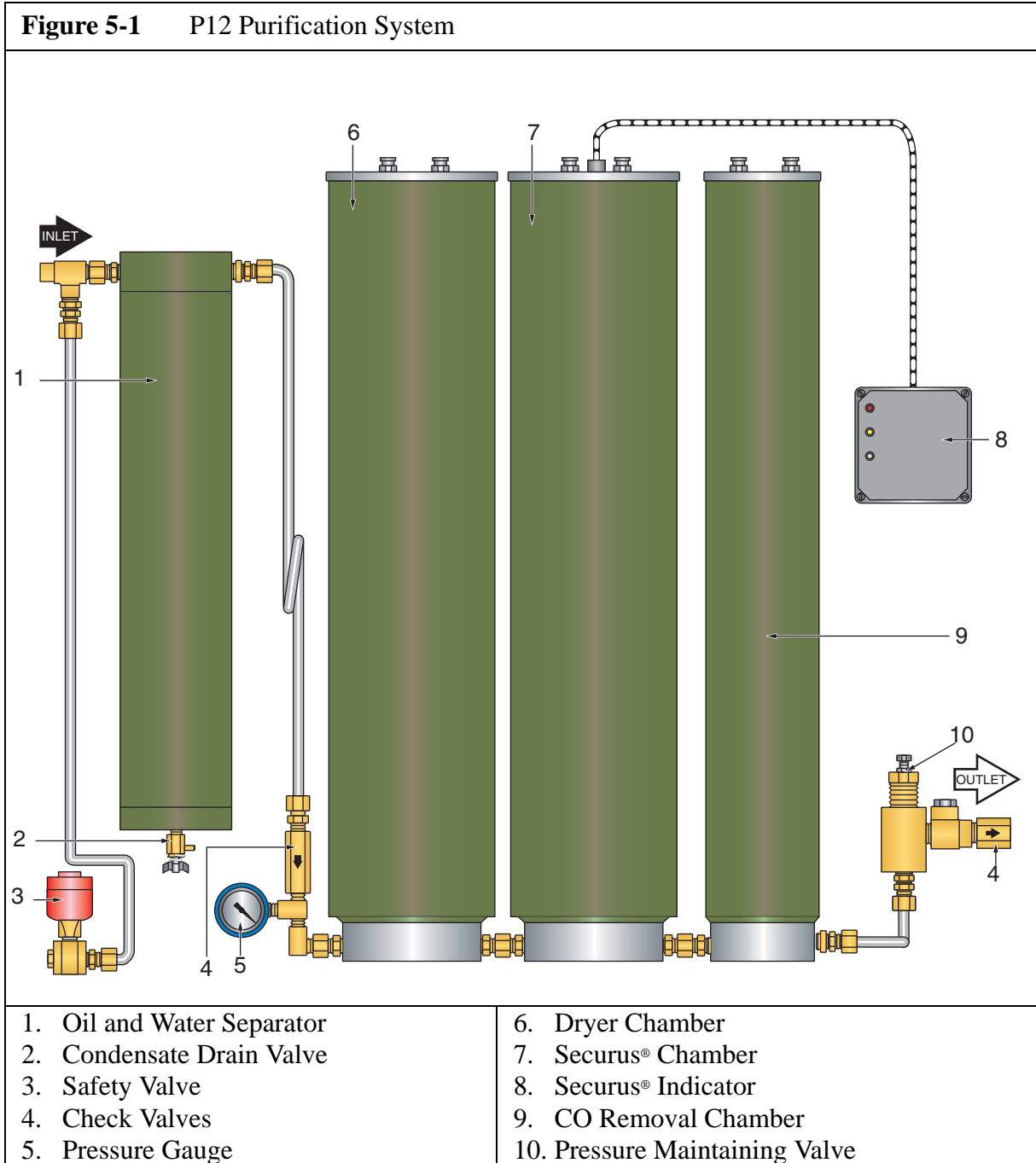

**5.2.1.1 Oil and Water Separator**

The coalescing oil and water separator uses a sintered metal filter to separate the liquid oil and water particles from the compressed air.

**5.2.1.2 Condensate Drain Valve**

A manually operated valve used before start-up and during operation to drain the condensed liquids from the coalescing oil and water separator. It is recommended not to drain the condensate more than four times per hour of operation.

**5.2.1.3 Check Valves**

Valves allowing compressed air to flow in only one direction. One is used to maintain pressure in the chamber when the compressor is not operating. The other prevents back-flow from filled storage.

**5.2.1.4 Dryer Cartridge**

The casings of the dryer cartridge as well as the cover and bottom are aluminum. The dryer cartridges are packed with molecular sieve which absorbs oil and water.

**5.2.1.5 Bleed Valve**

A manually operated valve used to release the pressure in the chamber before maintenance.

**5.2.1.6 Pressure Maintaining Valve**

The pressure maintaining valve ensures that pressure is built up in the purification system from the start of delivery, thus achieving constant optimum purification. It also assures proper working conditions for the final stage of compression.

**5.2.1.7 Safety Valve**

The safety valve is the safety valve for the final stage of the compressor.

**5.2.1.8 Securus® Electronic Moisture Monitor System**

The Securus® Electronic Moisture Monitor System warns the operator in advance of expiration of the life of the cartridges. The Securus® Indicator receives signals concerning the condition of the drying agent inside the Securus® cartridge from the attached sensors and supplies the appropriate control signals whenever the preset threshold values have been reached.

**5.2.1.9 Securus® Cartridge**

The Securus® Cartridge is packed with a catalyst which converts carbon monoxide to carbon dioxide, activated carbon which absorbs oil vapors, molecular sieve which absorbs oil and water and the sensor components of the Securus® Electronic Moisture Monitor System.

**5.2.1.10 Securus® Indicator**

The operating condition of the Securus® Electronic Moisture Monitor System is indicated by the color and state of four LED's on the front of the Securus® Indicator and is shown in the following table.

**NOTICE**

After applying power it will take about ½ second for the appropriate LED to illuminate. During this time the status of the Securus® Electronic Moisture Monitor System is tested.

Color	State	Indication	Compressor Unit Status
Green	Steady	Satisfactory	The unit is in operation
Yellow	Flashing	Cartridge Change Pre-warning	The unit is in operation. The green LED will also illuminate.
Red	Flashing	Cartridge Change Required	The unit is shutdown and can not be started until the cartridges are changed.
Red	Steady	Cable Failure or Missing Cartridge	The unit is shutdown.
No LEDs Illuminate		No operating voltage or electronic failure	The unit is shutdown.

## 5.2.2 Maintenance

### 5.2.2.1 Oil and Water Separator

1. The sintered metal micro-filter requires maintenance every 1000 hours. To remove the micro-filter element; proceed as follows.
2. Disconnect the power and shut off the inlet supply line if applicable. Depressurize the system by means of the bleed valve.
3. Remove the tubes connected to the side of the filter head. Unscrew and remove the filter head (1).
4. Unscrew the micro-filter element (2) from filter head. Unscrew the acorn nut (3) from the center stud to remove the micro-filter element. Unscrew the hex nuts (4) from the end plate to remove the filter inserts.
5. Clean the sintered filter element using hot soapy water. When cleaning the element, record the number of operating hours as indicated on the hourmeter to ensure exact attention to the maintenance intervals. Blow dry with compressed air.
6. Lubricate the o-rings with petroleum jelly. Apply sparingly. Dry the inside of the filter housing with a clean cloth and check for corrosion before reinstalling the micro-filter element. In the event you discover corrosion, replace the corroded parts with new BAUER parts.

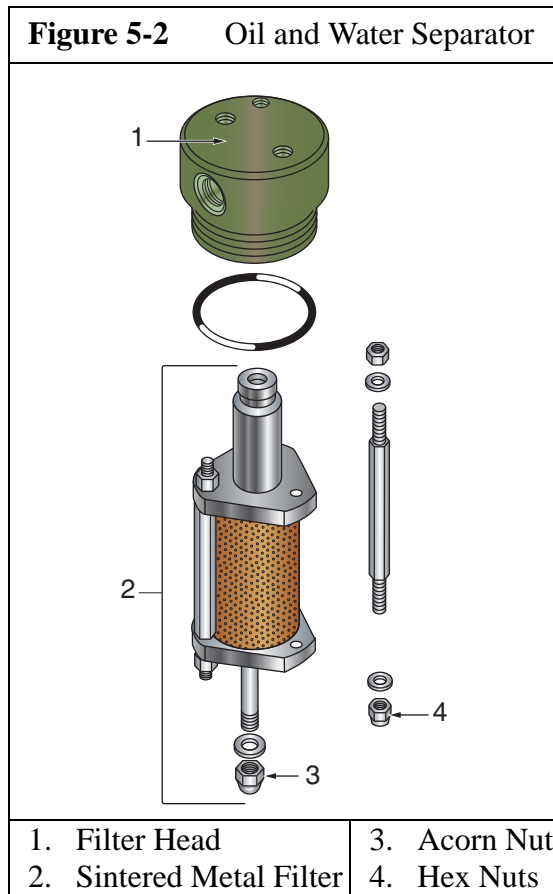

### 5.2.2.2 Chamber

To change the cartridge, proceed as follows. See Figure 5-3 Disconnect the power and shut off the inlet supply line, if applicable.

1. Depressurize the system by means of the bleed valve.
2. Unscrew the filter head using the Seccant Filter Key (P/N# 066690 or N29373).
3. Screw the supplied T-wrench (extraction key P/N# 067146) onto the threaded rod in the top of the cartridge. Pull out the cartridge with the T-wrench.
4. Dispose of the dirty cartridge in accordance with local, state, and federal regulations.
5. Dry the inside of the chamber with a clean cloth and check for corrosion.
6. Replace all corroded parts with new BAUER parts.
7. Remove the shipping covering from the new cartridge and remove the protective cap from the bottom of the cartridge.
8. Lubricate the O-rings with white petroleum jelly. Apply sparingly.
9. Firmly install the new cartridge. Be sure the cartridge snaps into place.
10. Reinstall the filter head.

11. Close the bleed valve, restore the power and reconnect the inlet supply line, if applicable.

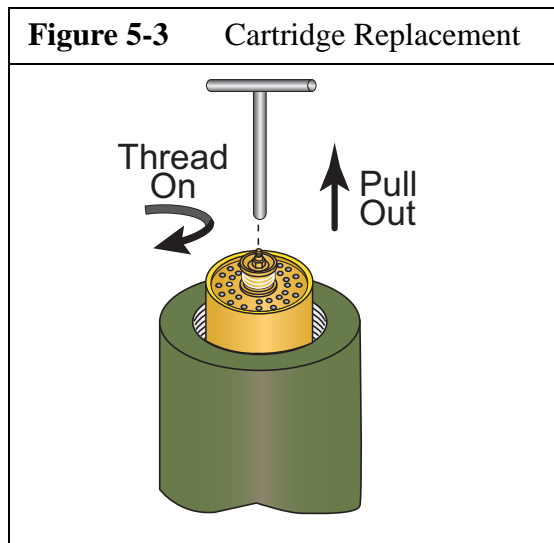
**NOTICE**

If air is detected bleeding out from the bottom of the chamber, the cartridge has not been installed properly or is missing. Follow the instructions in Paragraph 5.2.2.3.

**5.2.2.3** Cartridge Leaks after Installation

1. Remove the cartridge following steps 3.3. in Paragraph 5.2.2.2.
2. Install cartridge if it is missing.
3. Remove cartridge with the T-wrench and inspect O-rings.
4. Replace O-rings if necessary.
5. Ensure protective caps and devices have all been removed.
6. Replace cartridge following steps 8.7. to 11.11. in Paragraph 5.2.2.2.

5.2.3 Replacement Parts List

Figure 5-4 P12 Purification System

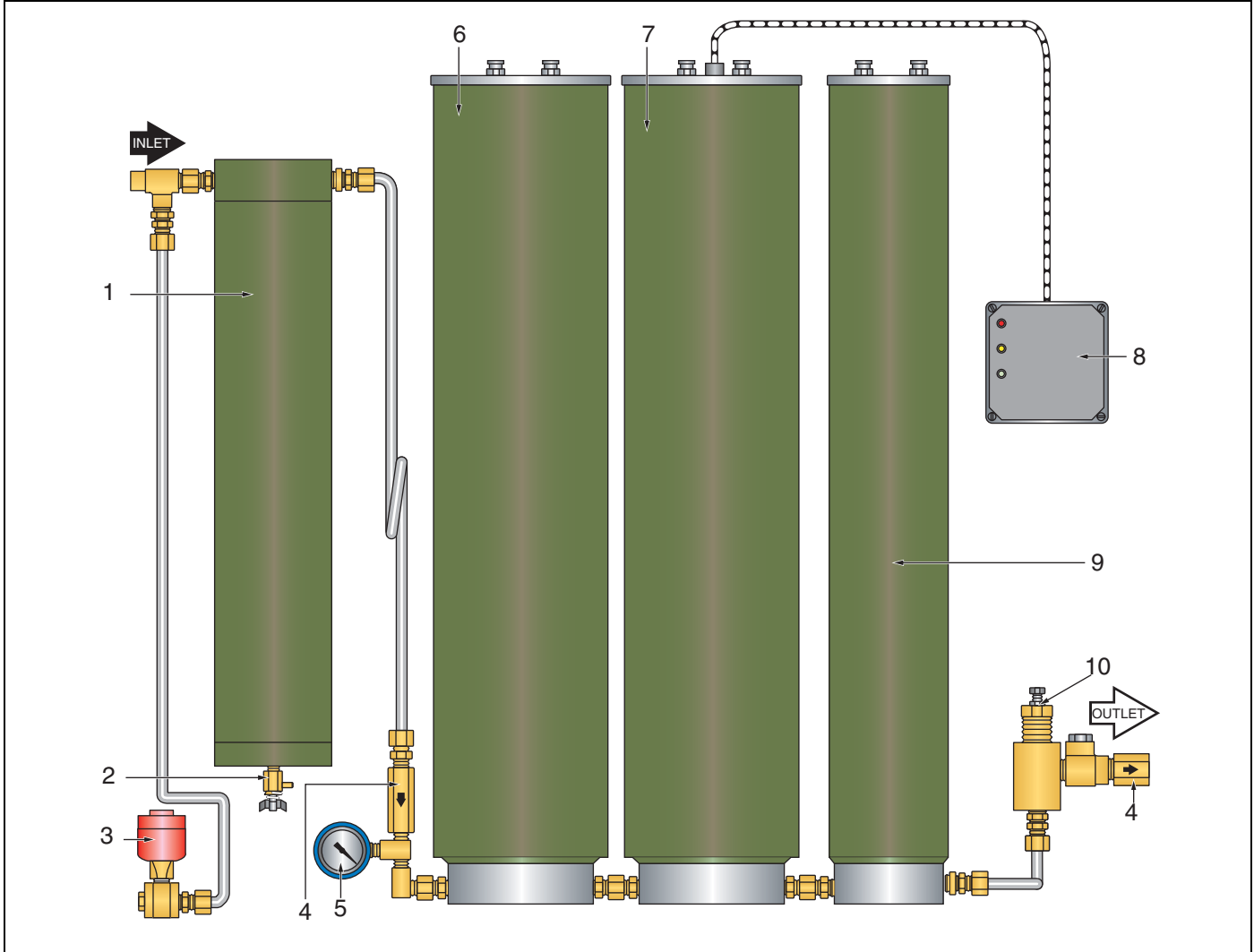

Item	Qty	Part No.	Description	Notes
1	1	055719	Oil and Water Separator	See Figure 5-5
2	1	011430	Condensate Drain Valve	
3	1	011523	Safety Valve	
4	2	VAL-0047	Check Valves	
5	1	GAG-0070W	Pressure Gauge	
6	1	067105	High Flow Dryer Chamber	See Figure 5-6
7	1	067106	High Flow Securus® Chamber	See Figure 5-7
8	1	N15095	Securus® Indicator	110 - 120VAC, 50 - 60 Hz
—	1	N15096	Securus® Indicator	12 - 24 VDC
9	1	080144	CO Removal Chamber	See Figure 5-8
10	1	VAL-0142	Pressure Maintaining Valve	

**Figure 5-5** Oil and Water Separator

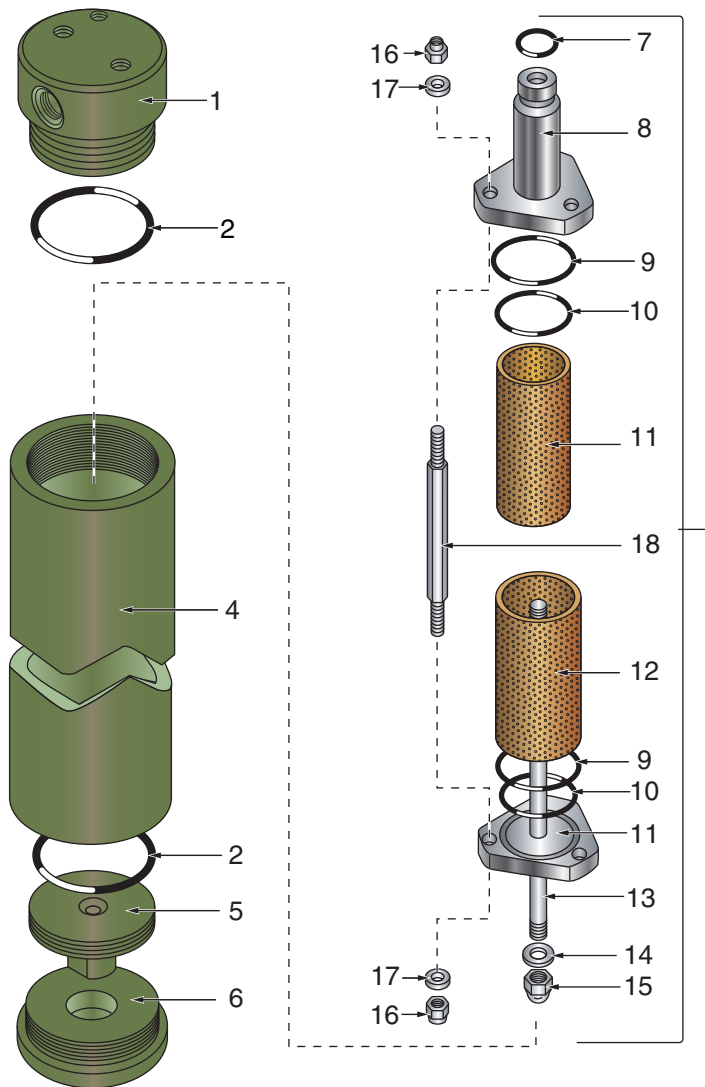

Item	Qty	Part No.	Description	Notes
◇	1	055719	Oil and Water Separator Assembly	
1	†	...	Separator Head	Available only with 055719
2	2	N02894	O-ring	
3	1	061839	Sintered Filter Element Assembly	Items 7 to 16
4	†	...	Separator Housing	Available only with 055719
5	†	...	Separator Bottom Plate	Available only with 055719
6	†	...	Separator Bottom Plug	Available only with 055719
7	1	N038600	O-ring	
8	1	061830	Filter Element Top	
9	2	N15541	O-ring	
10	2	N15540	O-ring	

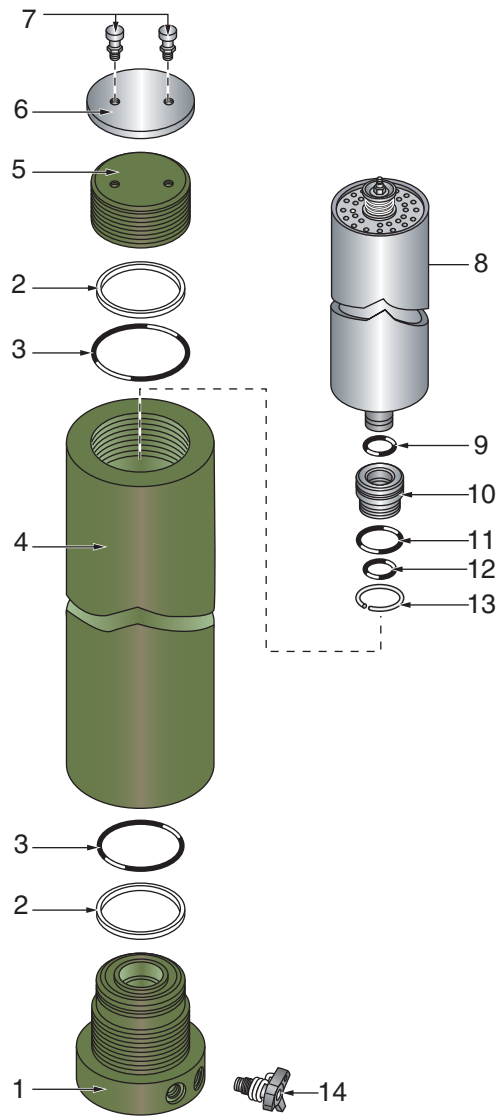

**Figure 5-5 (cont.)**

## Oil and Water Separator

<b>Item</b>	<b>Qty</b>	<b>Part No.</b>	<b>Description</b>	<b>Notes</b>
11	1	061836	Sintered Metal Filter Insert	
12	1	061837	Sintered Metal Filter Insert	
13	1	061831	Filter Element Bottom	
14	1	N15542	Usit Ring	
15	1	N00084	Acorn Nut	8 mm
16	6	NUT-0118	Hex Nut	6 mm
17	6	WAS-0024	Flat Washer	6 mm
18	3	061833	Hex Shaft	M6

**Figure 5-6** 27" High Flow Chamber Assembly



Item	Qty	Part No.	Description	Notes
◇	1	067105	Chamber Assembly	27" High Flow
1	†	...	Chamber Bottom Plug	Available only with 067105
2	2	N17456	Back-up Ring	
3	2	N17455	O-ring	
4	†	...	Chamber Housing	Available only with 067105
5	1	057065	Filter Head	
6	†	...	Cover Plate	Available only with 067105
7	2	012293	Tool Post Screw	
8	1	067099	Dryer Cartridge Assembly	MS/AC
9	1	N15205	O-ring	

**Figure 5-6 (cont.)**

## 27" High Flow Chamber Assembly

<b>Item</b>	<b>Qty</b>	<b>Part No.</b>	<b>Description</b>	<b>Notes</b>
10	1	067070	Sealing Cuff	
11	1	N17454	O-ring	
12	1	N17453	O-ring	
13	1	N17457	Retaining Ring	
14	1	065500	Bleed Valve	

**Figure 5-7** Securus® Chamber Assembly

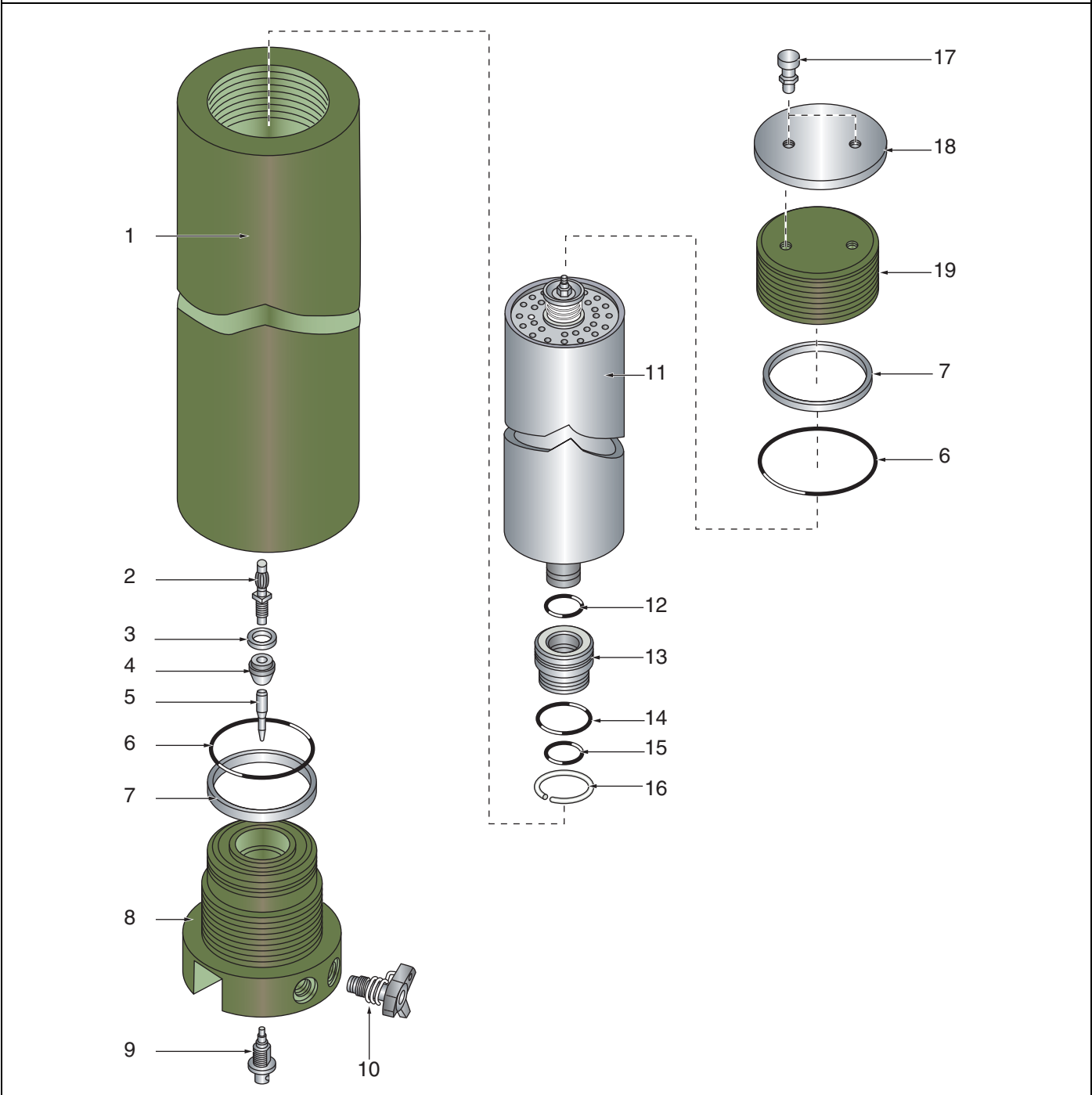

Item	Qty	Part No.	Description	Notes
◇	1	067106	Securus® Chamber Assembly	27" High Flow
1	†	...	Chamber Housing	Available only with 067106
2	1	N17458	Finned Plug	
3	1	067088	Round Nut	

Figure 5-7 (cont.)

## Securus® Chamber Assembly

Item	Qty	Part No.	Description	Notes
4	1	067072	Packing Sleeve	
5	1	067093	Tapered Pin	
6	2	N17455	O-ring	
7	2	N17456	Back-up Ring	
8	†	...	Chamber Bottom Plug	Available only with 067106
9	1	059850	Socket	RF Type
10	1	065500	Bleed Valve	
11	1	067097	Securus® Cartridge	MS/AC/MS
12	1	N15205	O-ring	
13	1	067070	Sealing Cuff	
14	1	N17454	O-ring	
15	1	N17453	O-ring	
16	1	N17457	Retaining Ring	
17	2	012293	Tool Post Screw	
18	†	...	Cover Plate	Available only with 067106
19	†	...	Chamber Head	Available only with 067106
N.S.	1	N15095	Securus® Indicator	110 - 120VAC, 50 - 60 Hz
—	1	N15096	Securus® Indicator	12 - 24 VDC

**Figure 5-8** CO Removal Chamber

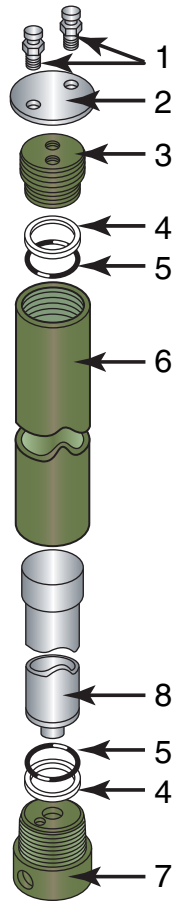

Item	Qty	Part No.	Description	Notes
◇	1	80144	27" Chamber Assembly	Items 1 - 7
1	2	012293	Tool Post Screw	
2	1	061237	Cover Plate	
3	†	...	Filter Head	Available only with 80144
4	2	N04736	Back-up Ring	
5	2	N04735	O-ring	
6	†	...	Filter Housing	Available only with 80144
7	†	...	Filter Bottom	Available only with 80144
8	1	065562	CO Removal Cartridge	HP/HP/HP

### 5.3 P14 Purification System

#### 5.3.1 Major Components

The P14 Purification System major components are an Oil and Water Separator, two Dryer Chambers and a Securus® Chamber. Figure 5-1 shows the functional interconnection of all the components. The Securus® Electronic Moisture Monitor System is standard.

**Figure 5-9** P14 Purification System

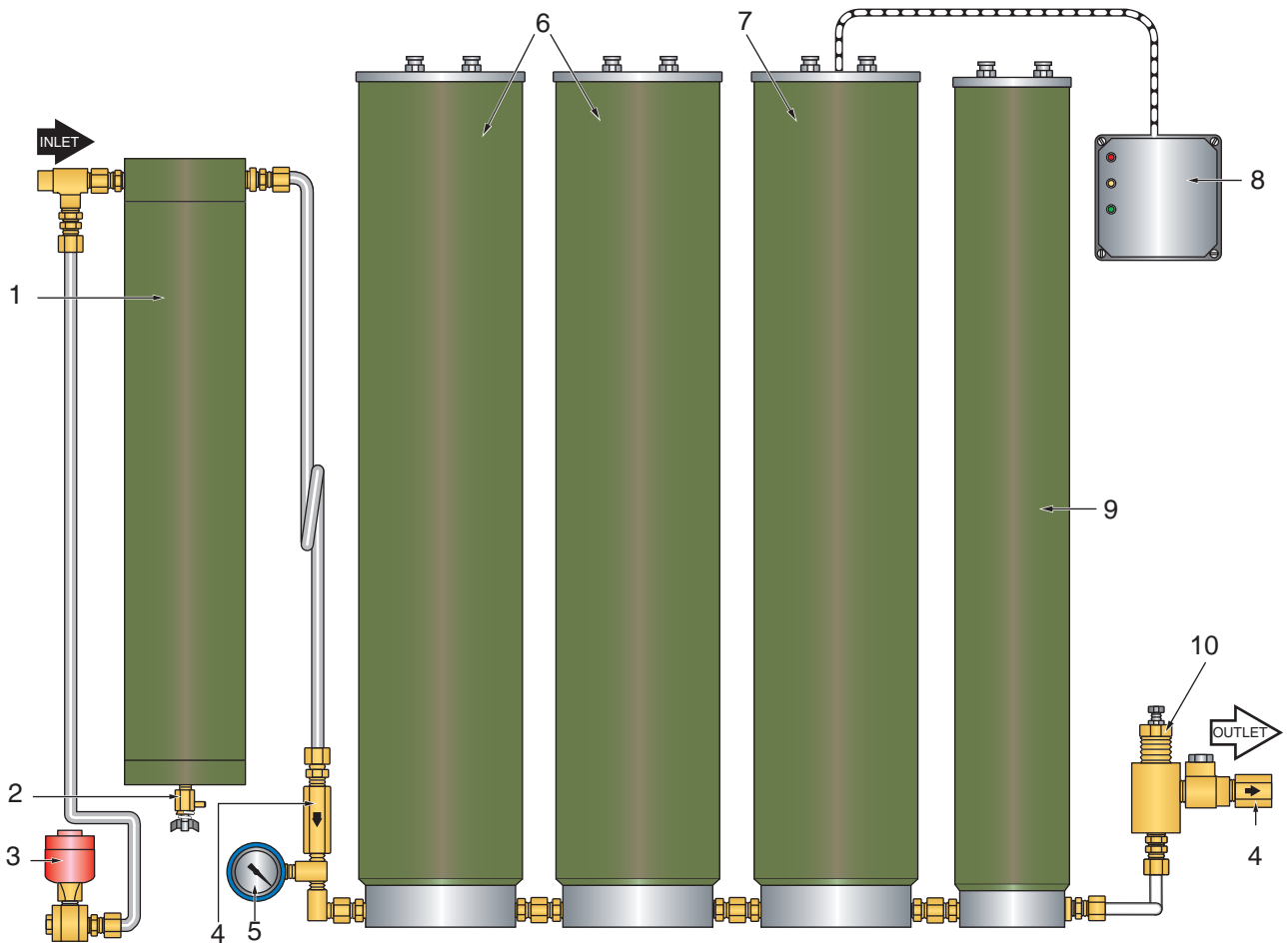

- 1. Oil and Water Separator
- 2. Condensate Drain Valve
- 3. Safety Valve
- 4. Check Valves
- 5. Pressure Gauge

- 6. Dryer Chambers
- 7. Securus® Chamber
- 8. Securus® Indicator
- 9. CO Removal Chamber
- 10. Pressure Maintaining Valve

**5.3.1.1 Oil and Water Separator**

The oil and water separator uses a sintered metal filter to separate the liquid oil and water particles from the compressed air.

**5.3.1.2 Condensate Drain Valve**

A manually operated valve used before start-up and during operation to drain the condensed liquids from the coalescing oil and water separator. It is recommended not to drain the condensate more than four times per hour of operation.

**5.3.1.3 Check Valves**

Valves allowing compressed air to flow in only one direction. One is used to maintain pressure in the chamber when the compressor is not operating. The other prevents back-flow from filled storage.

**5.3.1.4 Dryer Cartridge**

The casings of the dryer cartridge as well as the cover and bottom are aluminum. The dryer cartridges are packed with molecular sieve which absorbs oil and water.

**5.3.1.5 Bleed Valve**

A manually operated valve used to release the pressure in the chamber before maintenance.

**5.3.1.6 Pressure Maintaining Valve**

The pressure maintaining valve ensures that pressure is built up in the purification system from the start of delivery, thus achieving constant optimum purification. It also assures proper working conditions for the final stage of compression.

**5.3.1.7 Safety Valve**

The safety valve is the safety valve for the final stage of the compressor.

**5.3.1.8 Securus® Electronic Moisture Monitor System**

The Securus® Electronic Moisture Monitor System warns the operator in advance of expiration of the life of the cartridges. The Securus® Indicator receives signals concerning the condition of the drying agent inside the Securus® cartridge from the attached sensors and supplies the appropriate control signals whenever the preset threshold values have been reached.

**5.3.1.9 Securus® Cartridge**

The Securus® Cartridge is packed with a catalyst which converts carbon monoxide to carbon dioxide, activated carbon which absorbs oil vapors, molecular sieve which absorbs oil and water and the sensor components of the Securus® Electronic Moisture Monitor System.

**5.3.1.10 Securus® Indicator**

The operating condition of the Securus® Electronic Moisture Monitor System is indicated by the color and state of four LED's on the front of the Securus® Indicator and is shown in the following table.

**NOTICE**

After applying power it will take about ½ second for the appropriate LED to illuminate. During this time the status of the Securus® Electronic Moisture Monitor System is tested.



Color	State	Indication	Compressor Unit Status
Green	Steady	Satisfactory	The unit is in operation
Yellow	Flashing	Cartridge Change Pre-warning	The unit is in operation. The green LED will also illuminate.
Red	Flashing	Cartridge Change Required	The unit is shutdown and can not be started until the cartridges are changed.
Red	Steady	Cable Failure or Missing Cartridge	The unit is shutdown.
No LEDs Illuminate		No operating voltage or electronic failure	The unit is shutdown.

### 5.3.2 Maintenance

#### 5.3.2.1 Oil and Water Separator

1. The sintered metal micro-filter requires maintenance every 1000 hours. To remove the micro-filter element; proceed as follows. See Figure 5-2.
2. Unscrew the filter head using the Seccant Filter Key (P/N# 066690 or N29373).
3. Screw the supplied T-wrench (extraction key P/N# 067146) onto the threaded rod in the top of the cartridge. Pull out the cartridge with the T-wrench.
4. Unscrew the micro-filter element (2) from filter head. Unscrew the acorn nut (3) from the center stud to remove the micro-filter element. Unscrew the hex nuts (4) from the end plate to remove the filter inserts.
5. Clean the sintered filter element using hot soapy water. When cleaning the element, record the number of operating hours as indicated on the hourmeter to ensure exact attention to the maintenance intervals. Blow dry with compressed air.
6. Lubricate the o-rings with petroleum jelly. Apply sparingly. Dry the inside of the filter housing with a clean cloth and check for corrosion before reinstalling the micro-filter element. In the event you discover corrosion, replace the corroded parts with new BAUER parts.

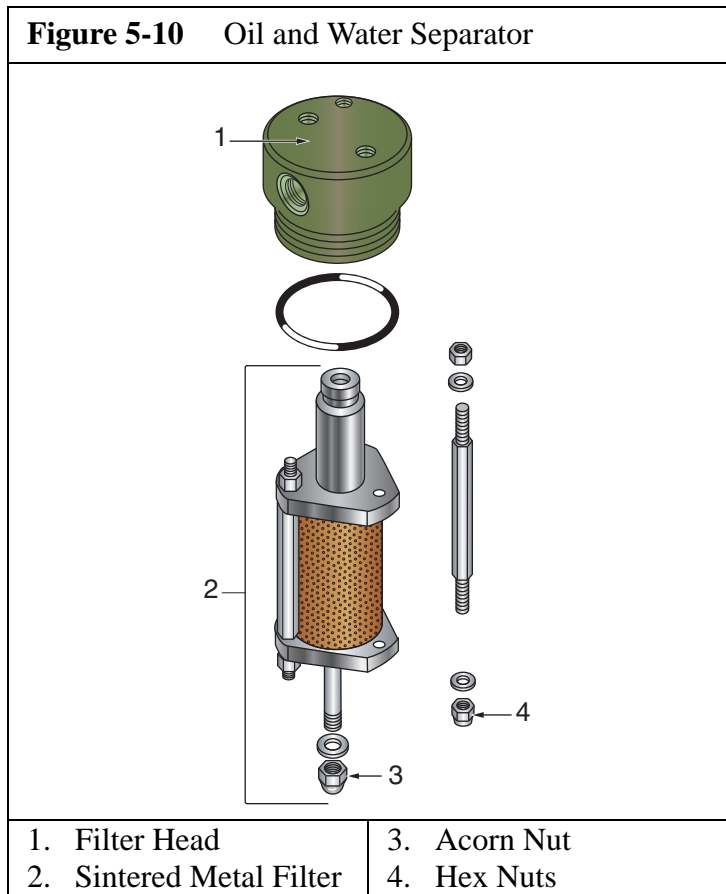

### 5.3.2.2 Chamber

To change the cartridge, proceed as follows. See Figure 5-11

1. Depressurize the system by means of the bleed valve.
2. Unscrew the filter head using the special wrench supplied.
3. Screw the supplied T-wrench onto the threaded rod in the top of the cartridge. Pull out the cartridge with the T-wrench.
4. Dispose of the dirty cartridge in accordance with local, state, and federal regulations.
5. Dry the inside of the chamber with a clean cloth and check for corrosion.
6. Replace all corroded parts with new BAUER parts.
7. Remove the shipping covering from the new cartridge and remove the protective cap from the bottom of the cartridge.
8. Lubricate the O-rings with white petroleum jelly. Apply sparingly.
9. Firmly install the new cartridge. Be sure the cartridge snaps into place.
10. Reinstall the filter head.
11. Close the bleed valve, restore the power and reconnect the inlet supply line, if applicable.

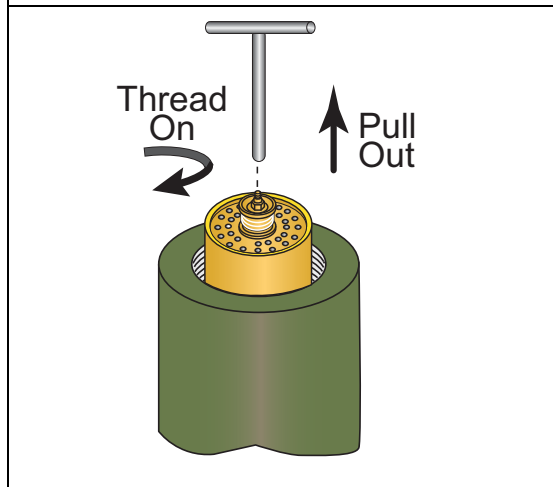
**Figure 5-11** Cartridge Replacement**NOTICE**

If air is detected bleeding out from the bottom of the chamber, the cartridge has not been installed properly or is missing. Follow the instructions in Paragraph 5.2.2.3.

**5.3.2.3** Cartridge Leaks after Installation

1. Remove the cartridge following steps 7 to 11 in Paragraph 5.2.2.2.
2. Install cartridge if it is missing.
3. Remove cartridge and inspect O-rings.
4. Replace O-rings if necessary.
5. Ensure protective caps and devices have all been removed.
6. Replace cartridge following steps 7 to 11 in Paragraph 5.3.2.2.

5.3.3 Replacement Parts List

Figure 5-12 P14 Purification System

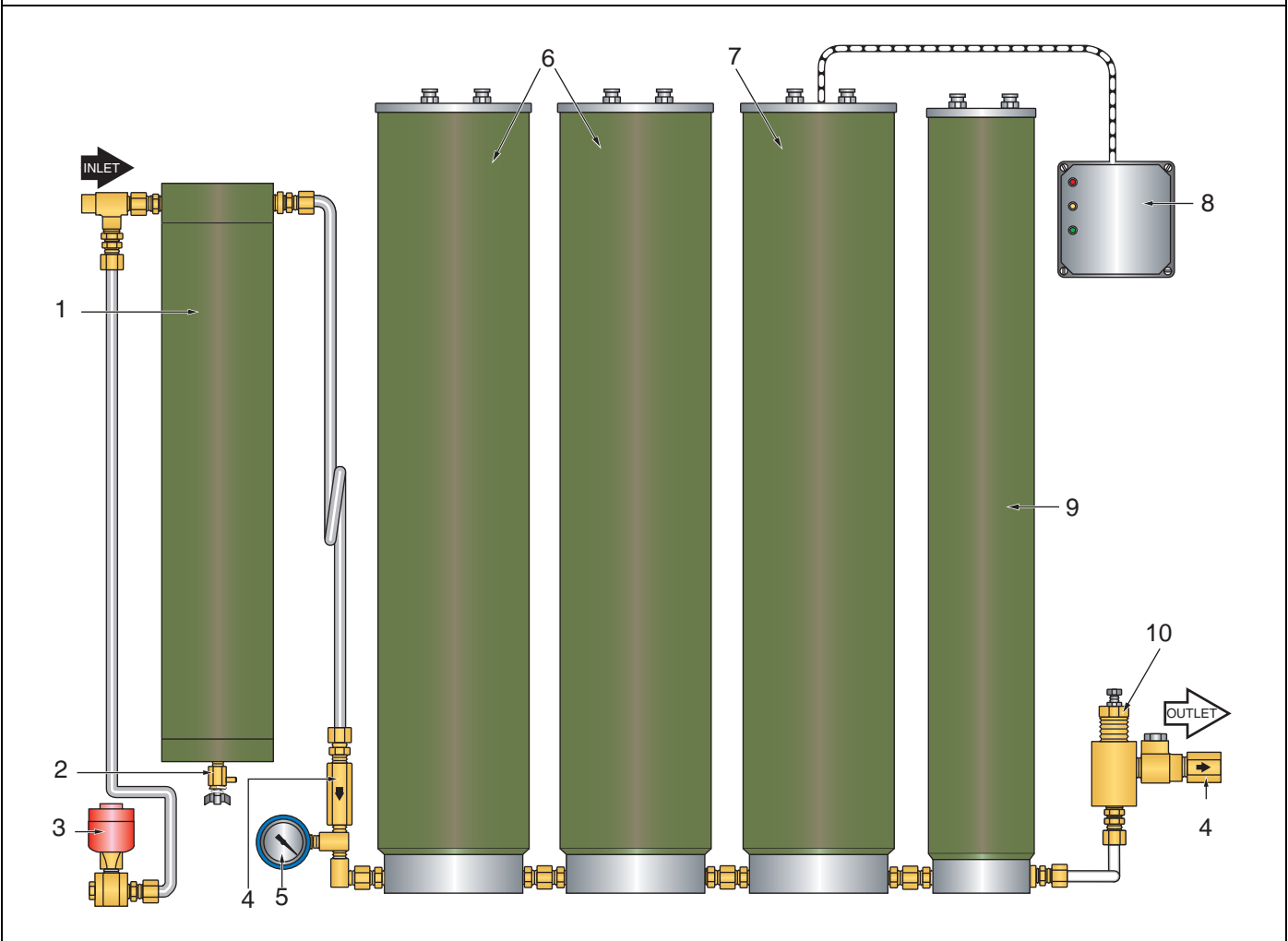

Item	Qty	Part No.	Description	Notes
1	1	055719	Oil and Water Separator	See Figure 5-13
2	1	011430	Condensate Drain Valve	
3	1	011523	Safety Valve	
4	2	VAL-0047	Check Valves	
5	1	GAG-0070W	Pressure Gauge	0 - 7500 psi
6	2	067105	High Flow Dryer Chamber	See Figure 5-14
7	1	067106	High Flow Securus® Chamber	See Figure 5-15
8	1	N15095	Securus® Indicator	110 - 120VAC, 50 - 60 Hz
—	1	N15096	Securus® Indicator	12 - 24 VDC
9	1	080144	CO Removal Chamber	See Figure 5-16
10	1	VAL-0142	Pressure Maintaining Valve	



**Figure 5-13** Oil and Water Separator

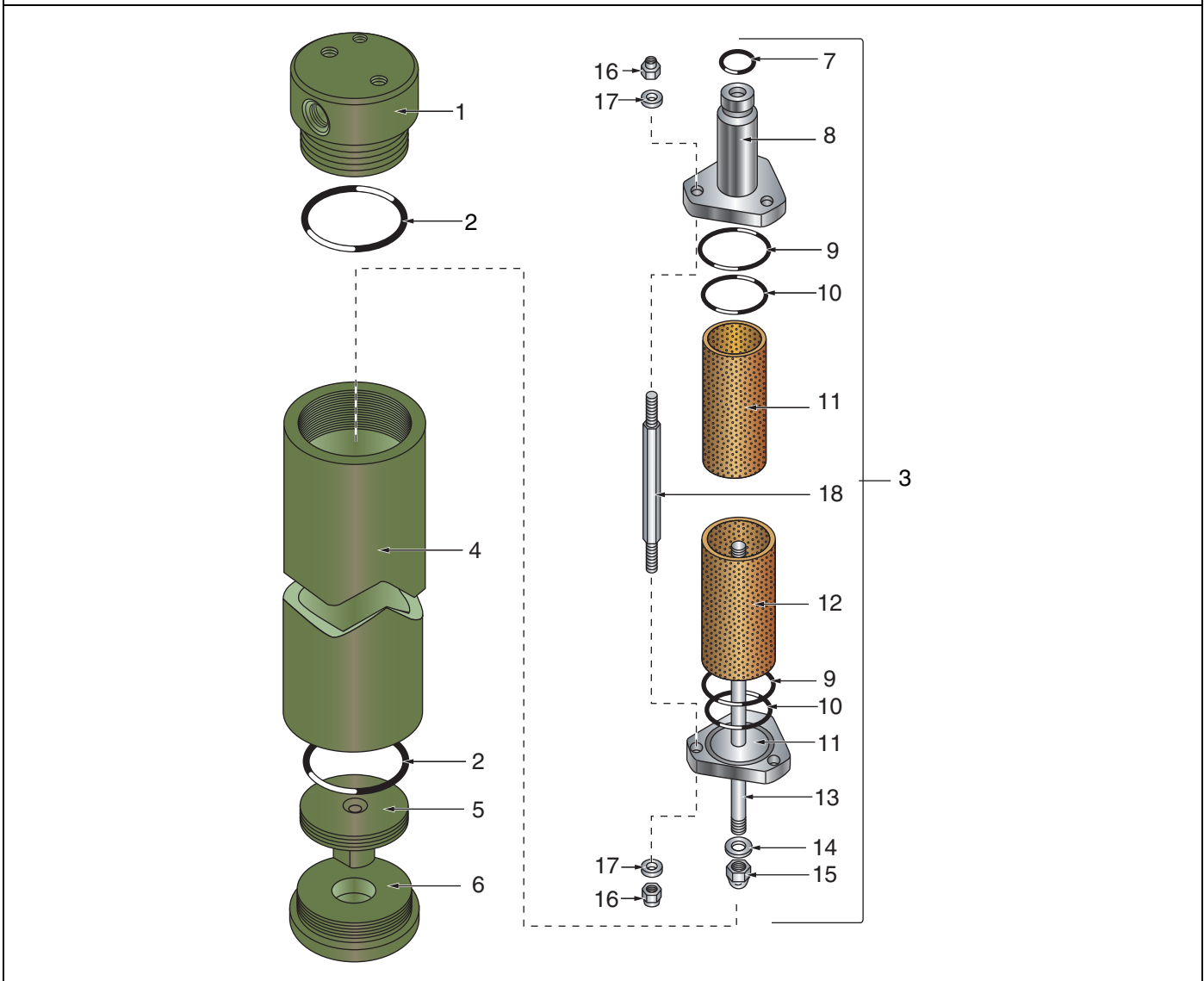

Item	Qty	Part No.	Description	Notes
◇	1	055719	Oil and Water Separator Assembly	
1	†	...	Separator Head	Available only with 055719
2	2	N02894	O-ring	
3	1	061839	Sintered Filter Element Assembly	Items 7 to 16
4	†	...	Separator Housing	Available only with 055719
5	†	...	Separator Bottom Plate	Available only with 055719
6	†	...	Separator Bottom Plug	Available only with 055719
7	1	N038600	O-ring	
8	1	061830	Filter Element Top	
9	2	N15541	O-ring	
10	2	N15540	O-ring	

**Figure 5-13 (cont.)** Oil and Water Separator

<b>Item</b>	<b>Qty</b>	<b>Part No.</b>	<b>Description</b>	<b>Notes</b>
11	1	061836	Sintered Metal Filter Insert	
12	1	061837	Sintered Metal Filter Insert	
13	1	061831	Filter Element Bottom	
14	1	N15542	Usit Ring	
15	1	N00084	Acorn Nut	
16	6	NUT-0118	Hex Nut	
17	6	WAS-0024	Flat Washer	
18	3	061833	Hex Shaft	

**Figure 5-14** 27" High Flow Chamber Assembly

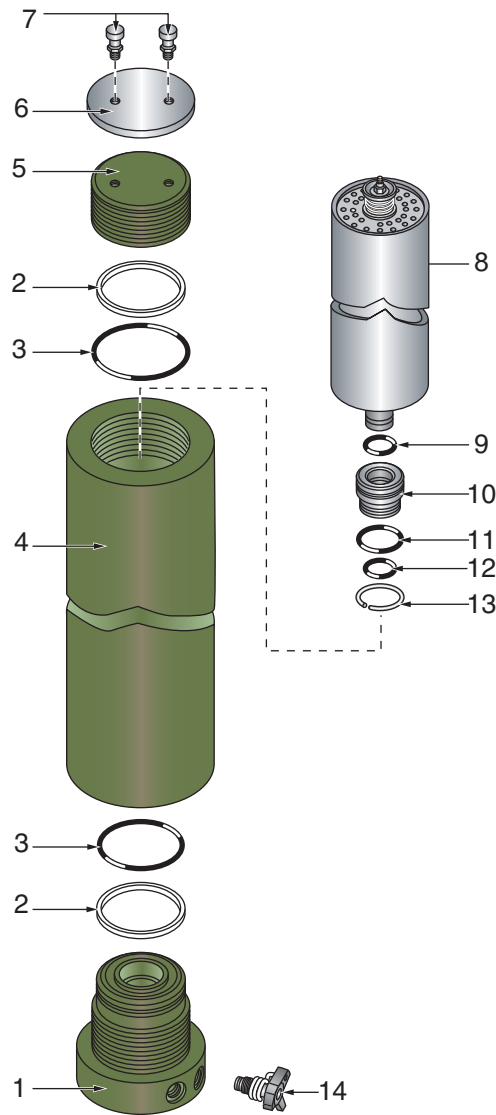

Item	Qty	Part No.	Description	Notes
◇	1	067105	High Flow Chamber Assembly	27"
1	†	...	Chamber Bottom Plug	Available only with 067105
2	2	N17456	Back-up Ring	
3	2	N17455	O-ring	
4	†	...	Chamber Housing	Available only with 067105
5	1	057065	Filter Head	
6	†	...	Cover Plate	Available only with 067105
7	2	012293	Tool Post Screw	
8	1	067099	Dryer Cartridge Assembly	MS/AC
9	1	N15205	O-ring	
10	1	067070	Sealing Cuff	



**Figure 5-14 (cont.)** 27" High Flow Chamber Assembly

<b>Item</b>	<b>Qty</b>	<b>Part No.</b>	<b>Description</b>	<b>Notes</b>
11	1	N17454	O-ring	
12	1	N17453	O-ring	
13	1	N17457	Retaining Ring	
14	1	065500	Bleed Valve	

**Figure 5-15** Securus® Chamber Assembly

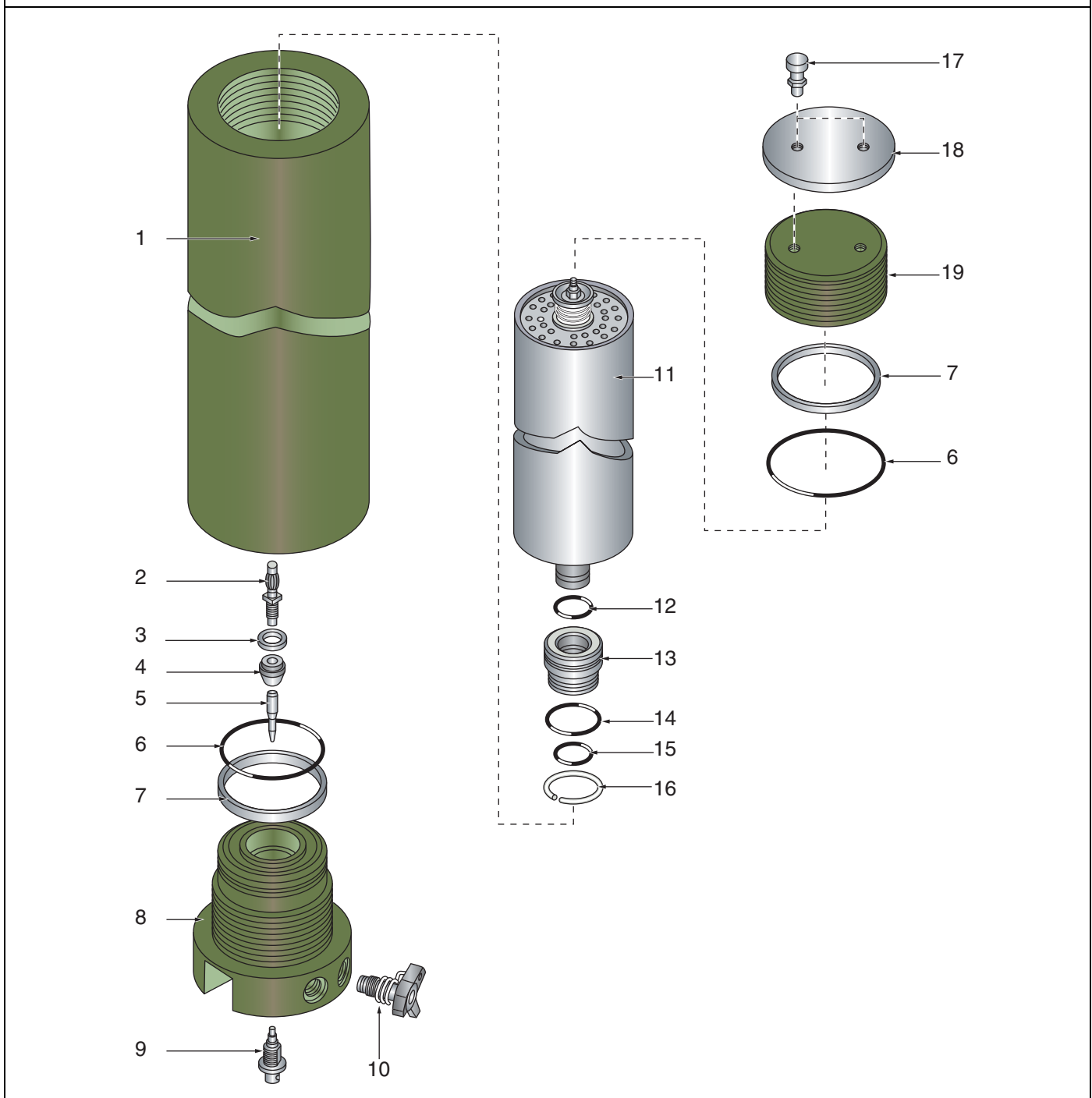

Item	Qty	Part No.	Description	Notes
◇	1	067106	Securus® Chamber Assembly	27" High Flow
1	†	...	Chamber Housing	Available only with 067106
2	1	N17458	Finned Plug	
3	1	067088	Round Nut	

Figure 5-15 (cont.)

## Securus® Chamber Assembly

Item	Qty	Part No.	Description	Notes
4	1	067072	Packing Sleeve	
5	1	067093	Tapered Pin	
6	2	N17455	O-ring	
7	2	N17456	Back-up Ring	
8	†	...	Chamber Bottom Plug	Available only with 067106
9	1	059850	Socket	RF Type
10	1	065500	Bleed Valve	
11	1	067097	Securus® Cartridge	MS/AC/MS
12	1	N15205	O-ring	
13	1	067070	Sealing Cuff	
14	1	N17454	O-ring	
15	1	N17453	O-ring	
16	1	N17457	Retaining Ring	
17	2	012293	Tool Post Screw	
18	†	...	Cover Plate	Available only with 067106
19	†	...	Chamber Head	Available only with 067106

**Figure 5-16** CO Removal Chamber

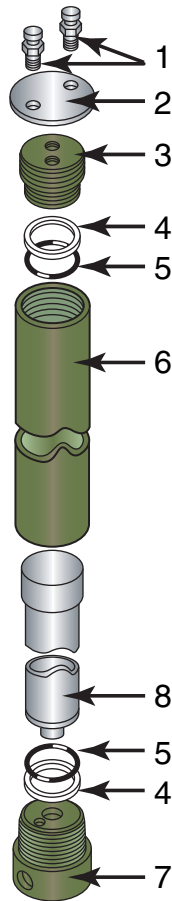

Item	Qty	Part No.	Description	Notes
◇	1	80144	27" Chamber Assembly	Items 1 - 7
1	2	012293	Tool Post Screw	
2	1	061237	Cover Plate	
3	†	...	Filter Head	Available only with 80144
4	2	N04736	Back-up Ring	
5	2	N04735	O-ring	
6	†	...	Filter Housing	Available only with 80144
7	†	...	Filter Bottom	Available only with 80144
8	1	065562	CO Removal Cartridge	HP/HP/HP

---

## CHAPTER 6: APPENDIX

### 6.1 Safety

#### 6.1.1 General Safety Precautions

- Read the operating manual before installing or operating this compressor unit. Follow appropriate handling, operation and maintenance procedures from the very beginning. The maintenance schedule contains measures required to keep this compressor unit in good condition. Maintenance is simple, but must be executed regularly to achieve safe operation, maximum efficiency and long service life.
- We recommend that all maintenance work be recorded in a service book, showing the date and details of the work carried out. This will help to avoid expensive repairs caused by missed maintenance work. If it is necessary to make a claim against the warranty, it will help to have proof that regular maintenance has been carried out and that the damage has not been caused by insufficient maintenance.
- This compressor unit must be installed, operated, maintained and repaired only by authorized, trained and qualified personnel.
- Consult and follow all OSHA, NEMA, ASME and local regulations, laws and codes covering the installation and operation of this compressor and accessories before operating the unit.
- Do not operate this unit in excess of its rated capacity, speed, pressure, temperature, or otherwise than in accordance with the instructions contained in this manual. Operation of this unit in excess of the conditions set forth in this manual will subject the unit to limits which it may not be designed to withstand.
- Keep safety guards in place.
- Do not modify the compressor or its systems.
- Do not wear loose clothing around machinery. Loose clothing, neckties, rings, wrists watches, bracelets, hand rags, etc. are potential hazards.
- Provide adequate fire protection. Make sure fire extinguishers are accessible. Select alternate routes of escape and post such routes.
- Make sure you are equipped with all required safety equipment; hearing protection, safety glasses, hard hats, safety shoes and fire extinguisher.
- Visually inspect the unit before starting. Remove and /or replace any loose or broken components, tools, valves, missing equipment, etc.
- Do not tamper with, modify, or bypass safety and shutdown equipment.
- Do not tighten or adjust fitting or connections under pressure.
- The use of plastic pipe or rubber hose in place of steel tube or iron pipe, soldered joints or failure to insure system compatibility of flex joints and flexible hose can result in mechanical failure, property damage, and serious injury or death.
- The use of plastic or nonmetallic bowls on line filters without metal guards can be dangerous.
- Replace damaged fan blades promptly. Fan assemblies must remain in proper balance. An unbalanced fan can fly apart and create an extremely dangerous condition.

- Allow the compressor to cool before servicing. Whenever the compressor is shut down and overheating is suspected, a minimum period of 15 minutes must elapse before opening the crankcase. Premature opening of the crankcase of an overheated unit can result in an explosion.
- Incorrect placement of the inlet and pressure valves in a compressor cylinder head can cause an extremely dangerous condition. Refer to the appropriate section of this manual before installing or replacing valves.
- Before doing any work involving maintenance or adjustment, be sure the electrical supply has been disconnected, and the complete compressor system has been vented of all internal pressure. Failure to follow these warnings may result in an accident causing personal injury and/or property damage.
- Before working on the electrical system, be sure to disconnect the electrical supply from the system at the circuit breaker or other manual disconnect. Do not rely on the ON/OFF switch to disconnect the electrical supply.
- Installer must provide an earth ground and maintain proper clearance for all electrical components.
- All electrical installation must be in accordance with recognized national, state, and local electrical codes.
- Do not use gasoline, diesel fuel or other flammable products as a cleaning solution.
- A compressor which has been used for gas service is unsuitable for air applications. Should the purchaser and/or user proceed to use the compressor for air service after it has been used for gas, the purchaser/user assumes all liability resulting therefrom without any responsibility being assumed by Bauer Compressors, Inc. The purchaser is urged to include the above provision in any agreement for resale of this compressor.
- The use of repair parts other than those listed in this manual or purchased from BAUER Compressors, Inc. may create unsafe conditions over which BAUER has no control. Such unsafe conditions can lead to accidents that may be life-threatening, cause substantial bodily injury, and/or result in damage to the equipment. Therefore, BAUER Compressors, Inc. can bear no responsibility for equipment in which non-approved repair parts are installed

**6.1.2 Safety Warning Labels**

Notes, labels and warning signs are displayed on the compressor unit according to model, application or equipment and may include any of the following.

	<p><b>HOT SURFACES DO NOT TOUCH!</b></p> <p>Danger of burning if cylinders, cylinder heads, or pressure lines of individual compressor stages are touched.</p>
	<p><b>HIGH VOLTAGE!</b></p> <p>Life threatening danger of electrical shock. Maintenance work on electric units or operating equipment should be carried out by a qualified electrician or by a person supervised by a qualified electrician according to electrical regulations.</p>
	<p><b>AUTOMATIC COMPRESSOR CONTROL UNIT MAY START WITHOUT WARNING!</b></p> <p>Before carrying out maintenance and repair work, switch off at the main switch and ensure the unit will not restart.</p>
	<p><b>THE INSTRUCTIONS MUST BE READ BEFORE OPERATING UNIT!</b></p> <p>The instruction manual and all other applicable instructions, regulations, etc. must be read and understood by the operating personnel before using the machine.</p>
	<p><b>HEARING PROTECTION MUST BE WORN!</b></p> <p>Hearing protectors must be worn when working on a machine which is running.</p>
	<p><b>DIRECTION OF ROTATION!</b></p> <p>When switching on the machine, check the arrow to ensure correct direction of rotation by the drive motor.</p>

## 6.2 Unpacking, Handling and Installation

### 6.2.1 Unpacking and Handling

This unit is packaged according to the requirements for shipping via the requested type of carrier service. It is possible that the unit could have been damaged during shipping. For this reason, we urge you to thoroughly examine the unit for possible damage and report any such damage to the shipping company immediately.

Care must be taken in unpacking the unit. Serious damage could result by not checking for clearance between the item being unpacked and the packaging to be removed.

Handling of the unpacked unit should be performed using only the following devices, see Figure 6-1.

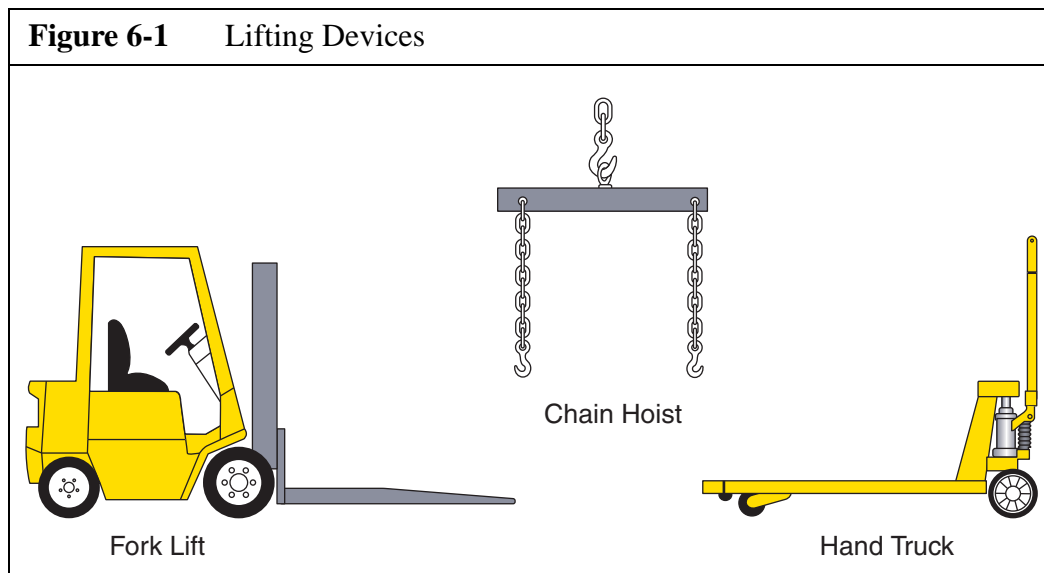

### **⚠ WARNING**

Be sure the lifting devices are capable of handling the weight of the unit (see Paragraph 1.4 for the weight of the unit). Before lifting the unit, secure all loose or swinging parts to keep them from moving. Stay clear of lifted load.

The unit may be furnished with one or more shipping braces for shipping and handling only. After installation and before operation, these braces must be removed entirely. Under no circumstances should the braces remain installed during operation or the manufacturer's warranty for the unit will be voided. The braces are all tagged and labeled.

### 6.2.2 Installation of the Unit

#### 6.2.2.1 General

The floor/site must be capable of supporting the weight of the unit. Position the unit so that it is level.

Observe and maintain an ambient temperature range of 43° to 113° F.

The area in which the compressor unit is installed should be well lit and easily accessible to facilitate servicing and routine maintenance.

#### 6.2.2.2 Electrical Installation



When making the electrical connections to the system, the following instructions are mandatory:

- Comply with all local, state and federal regulations concerning electrical installation.
- Arrange for the electrical connections to be made by a certified electrician only.
- Ensure that the motor voltage, control unit voltage, and frequency conform with the main voltage and frequency. Do not connect the unit to a voltage other than the one specified on the nameplate.
- Provide all necessary cables and main fuses and a master disconnect switch. The fusing of the compressor must be carried out in compliance with local, state and national electrical regulations.

#### **6.2.2.2.1 Electrical Supply**

The machine is factory wired according to order. If the voltage is to be changed, consult the factory for instructions and necessary parts.

### **6.3 Long Term Storage**

#### **6.3.1 General**

If the compressor unit will be out of service for more than six months, it should be preserved in accordance with the following instructions:

1. Make sure that the compressor is kept indoors in a dry, dust-free room.
2. Cover the compressor with plastic sheets only if no condensation will form under the sheet.
3. Remove the sheet from time to time and clean the outside of the unit.
4. If this procedure cannot be followed, or if the compressor will be out of service for more than 24 months, please contact the BAUER Service Department for special instructions.

#### **6.3.2 Preparations**

Prior to preserving the compressor unit, it must be run until warm, i.e., up to the specified service pressure. Operate the unit for approximately 10 minutes, then carry out the following checks.

1. Check all pipes, filters and valves (including safety valves) for leakage.
2. Tighten all couplings, as required.
3. After 10 minutes, open the outlet valve and operate the compressor at adjusted minimum pressure using the pressure maintaining valve for approximately 5 minutes.
4. After the 5 minutes, shut the compressor unit down and completely drain all separators and filters. Close all valves.
5. Remove filter heads and lubricate the threads with petroleum jelly.

#### **6.3.2.1 Units Equipped with a Filter System**

1. Ensure that cartridges remain in the purification system chambers. This will prevent oil from entering the outlet lines as a result of preservation procedures.
2. Remove the intake filter/intake pipe completely.

#### **6.3.3 Preserving the Compressor**

1. Operate the compressor again and slowly spray approximately 0.35 oz. (10 cc) of oil into the inlet port while the compressor is running. Keep the shut-off valve open and the condensate drain valves closed.
2. After spraying the oil into the inlet port, run the compressor unit for an additional 5 minutes before shutting the compressor unit down.
3. Close the shut-off valve.
4. Close the inlet port with a dust cap and/or tape.

#### **6.3.4 Preventive Maintenance During Storage**

Operate the compressor once every six months as follows:

1. Remove the dust cap from the inlet port and install the inlet filter.
2. Open the outlet valve and allow the system to run approximately 5 minutes until there is outflow from the valve and oil is visible in the sight glass of the oil regulating valve.
3. Shut down the compressor.
4. Open the condensate drain valves, depressurize the unit, then close the drain valves again.
5. Remove the intake filter and replace the dust cap on the inlet port.

#### **6.3.5 Lubrication Oils for Preservation**

1. After prolonged storage periods, the oil will age in the compressor crankcase. The oil must be drained at least every 24 months and replaced with fresh oil.
2. The stated period can only be attained when the crankcase is sealed during the preservation period in accordance with the preservation requirements.
3. After changing the oil, the compressor must be operated according to the instructions above.
4. Check the lubrication of the compressor during the every-six-month brief operation.
5. The oil pump is functioning properly when oil can be seen flowing through the sight glass of the oil pressure regulator or if the oil pressure gauge indicates the prescribed pressure.

#### **6.3.6 Reactivating the Compressor Unit**

1. Remove the dust cap from the inlet port and install the intake filter.
2. Check the oil level of the compressor. If necessary, change the oil.
3. The motor must be thoroughly dry before applying power.
4. For units with a purification system, change all cartridges.
5. Run the compressor with open outlet valve for approximately 10 minutes. Check for proper operation of the lubricating system.
6. After 10 minutes, close the shut-off valve and run the system up to final pressure until the final pressure safety valve vents. On compressor units with a compressor control system, raise the pres-

---

sure switch setting the switch above normal limits to override the pressure switch. Be sure to reset the switch after checking.

7. Check the interstage safety valves for leakage.
8. Establish the cause of any faults and remedy.
9. Stop the unit when it is running properly. The compressor is then ready for operation.

**6.4 Reference Data**

**6.4.1 Tightening Torque Values**

1. Unless otherwise specified in text, the torque values in Table 1 apply.
2. The indicated torque values are valid for bolts in greased condition.
3. Self locking nuts must be replaced on reassembly
4. Pipe connections (swivel nuts) should be tightened just enough so that leakage is stopped. Not more than finger tight plus up to an additional 1/2 turn.

Bolt or Screw	Size	Max. Torque
Hex and socket head	1/4" (M 6)	7 ft. lbs. (10 Nm)
Hex and socket head	5/16" (M 8)	18 ft. lbs. (25 Nm)
Hex and socket head	3/8" (M 10)	32 ft. lbs. (45 Nm)
Hex and socket head	1/2" (M 12)	53 ft. lbs. (75 Nm)
Hex and socket head	9/16" (M 14)	85 ft. lbs. (120 Nm)
Hex and socket head	5/8" (M 16)	141 ft.-lbs (200 Nm)

**Table 6-1:** Torque Values

**6.4.2 Torque Sequence Diagrams**

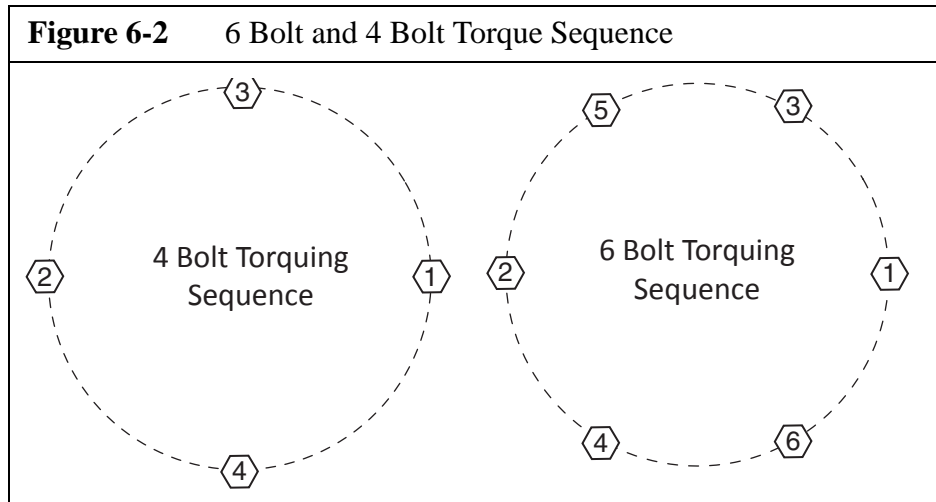

**6.4.3 Conversion Formulas**

$$^{\circ}\text{F} = 9/5^{\circ}\text{C} + 32$$

$$\text{PSI} = \text{BAR} \times 14.5$$

$$^{\circ}\text{C} = 5/9 \times (^{\circ}\text{F} - 32)$$

$$\text{BAR} = \text{PSI} \times 0.0689$$

#### 6.4.4 Approved Lubricants Chart

Unless otherwise specified in text, use the lubricants in Table 2.

Usage	Lubricants
O-rings, rubber and plastic parts; filter housing threads, sealing rings	Parker Super "O" Lube or petroleum jelly
Bolts, nuts, studs, valve parts, copper gaskets and tube connection parts (threads, cap nut and compression rings)	Never-Seez® NSWT, Pipe Dope or teflon tape
Paper gaskets	DOW Corning 732 or equivalent silicon compound applied on both sides before assembly,
High temperature connections	DOW Corning 732 or equivalent temperature resistant compound,
Tube connection ferrules,	Never-Seez® NSWT
<b>Table 6-2: Lubricant Chart</b>	

#### 6.4.5 Glossary of Abbreviations and Acronyms

†	Available Only as Part of a Complete Assembly
AC	Activated Charcoal, removes odor and taste
ACD	automatic condensate drain
ASME	American Society of Mechanical Engineers
CW	clockwise
CCW	counterclockwise
CGA	Compressed Gas Association
DIN	Deutsches Institut für Normung
DOT	Department of Transportation
E1	single phase electrical supply
E3	three phase electrical supply
HP	Chemical Catalyst, converts carbon monoxide to carbon dioxide
IAW	In Accordance With
MS	Molecular Sieve, removes moisture
NEC	National Electrical Code
NEMA	National Electrical Manufacturers Association
NFPA	National Fire Protection Association
OSHA	Occupational Safety & Health Administration
ODP	open drip-proof (motor)
OEM	Original Equipment Manufacturer
PCB	printed circuit board
PLC	Programable Logic Controller
PMV	pressure maintaining valve
SC	Securus® Moisture Sensing Device

**6.5 Additional Documents****6.5.1 Diagrams and Drawings**

Any included drawings, wiring diagrams, pneumatic flow diagrams, etc., will be bound next to the back cover in a hardcopy manual or included as a separate file on a CD.

**6.5.2 Other Documents**

OEM Manuals and other BAUER manuals may be included in the documentation shipping package.

# CORRECTIONS & COMMENTS

In an effort towards constant improvement, the Documentation section of Bauer Compressors, Inc. would like to give you the opportunity to suggest improvements or corrections to this manual. If you find any inaccuracies or have suggestions feel free to E-mail us at: *documentation@bauercomp.com*, or fill out the form below and mail it to us:

### Submitters Contact Information:

Name: \_\_\_\_\_

Address: \_\_\_\_\_

(number & street)

\_\_\_\_\_

(city, state \ zip)

E-mail: \_\_\_\_\_

(optional)

### Unit Information:

Model: \_\_\_\_\_

Serial#: \_\_\_\_\_

Block#: \_\_\_\_\_

MFG Date: \_\_\_\_\_

Inaccuracies: page# \_\_\_\_\_ figure# \_\_\_\_\_ paragraph# \_\_\_\_\_

---

---

---

---

---

---

Suggested Corrections: \_\_\_\_\_

---

---

---

---

---

---

Additional Comments: \_\_\_\_\_

---

---

---

---

---

---

fold here



place  
postage  
here

**Bauer Compressors, Inc.**  
**Attn: Documentation**  
**1328 Azalea Garden Rd.**  
**Norfolk, VA 23502-1944**

fold here



tape or glue here