

# OPERATION AND MAINTENANCE

## MODEL 873-150 REGULATOR

The model 873 is a piston type hand loading regulator. It utilizes a balanced poppet design for high flow and minimum effect of inlet pressure on outlet pressure. The poppet assembly is contained in a cartridge with internal filtration for easy in-field changing. The regulator is self venting but is optionally available without the vent.

### SPECIFICATIONS

- Maximum inlet pressure 6000 PSI (40 MPa)
- Outlet pressure 0 to 150 PSI (1 MPa)
- Flow coefficient ( $C_v$ ) 0.8  
(equivalent to 0.23" orifice)
- Rise of outlet pressure with drop of inlet pressure 3 PSI/1000 PSI
- Materials - body and cap - aluminum  
internals - brass, stainless,  
seals, - KEL-F, Viton
- Fittings 1/4" FNPT inlet  
1/2" FNPT outlet
- Size 3" dia x 6" lg

### INSTALLATION

Use a suitable pipe thread sealant such as teflon tape on inlet and outlet threads. Avoid over torquing pipe thread. Normal torque applied with a 6 or 8 inch long wrench is ample. Use ample teflon tape - 3 or 4 turns, not 1 or 2 turns. The inlet is on the left when facing the adjusting knob with the two gage ports upward. An optional panel mounting nut is available (part no. 952). This nut permits mounting the regulator using a 1.25" hole in a panel or plate. The regulator is NOT shipped oxygen clean and should NOT be used for oxygen service as provided. Consult the factory for details on oxygen service. The 1/2" port is the outlet. The 1/4" port adjacent to the 1/2" port is the outlet gauge port. The other two 1/4" ports are the inlet and inlet gauge ports. Either of these ports can be used as the inlet. Connect the inlet to the source gas such as a high pressure storage tank. The outlet is capable of being adjusted from 0 to 150 PSI. AN OUTLET GAUGE AND RELIEF VALVE SET NO HIGHER THAN 150 PSI SHOULD BE CONNECTED TO THE OUTLET. A 1/2" NPT SIZE RELIEF VALVE SHOULD BE USED FOR FULL PROTECTION. IF THE INLET PRESSURE CAN EXCEED 6000 PSI A RELIEF VALVE SHOULD ALSO BE INSTALLED AT THE INLET TO PREVENT EXCEEDING 6000 PSI.

### OPERATION

Outlet pressure is adjusted by knob 10 (refer to drawing) to the desired value as read on the outlet gauge. When reducing the pressure the regulator will self vent via the vent hole near the cap. This is normal. When reducing set pressure reduce pressure to below the new setting then increase pressure to the new setting. If in-field adjustment is to be avoided, the knob 10 can be replaced by a bolt and lock nut. A 3/8" by 24 thread per inch bolt with a minimum thread length if one inch is required.

### MAINTENANCE & REPAIR

**CAUTION** As with any regulator or valve, particulates or moisture can plug or freeze the internal filter or valve seat. This can occur when up-stream dryers are not changed or remain unused for long periods allowing corrosion materials to accumulate. In critical applications where it is important not to lose flow, a larger particulate filter should be used upstream. Also an orifice such as the Aqua model 796 should be used downstream. This reduces the tendency to freeze when moisture is present. Consult factory for details. The user should establish time intervals for changing the valve cartridge, filter and upstream dryers based on experience and service conditions. No representation is made herein as to time intervals as each use is unique. Back-up systems should be used in very critical applications since field maintenance is hard to insure. The poppet cartridge 895 is a factory assembled item and should be replaced if required and not disassembled unless absolutely necessary. Spare cartridges are available at a nominal cost and should be kept on hand if rapid repairs are required. IN ALL CASES THE UNIT CAN BE RETURNED TO THE FACTORY OR DEALER FOR REPAIR UNDER WARRANTY IF APPLICABLE OR AT A NOMINAL CHARGE. Maintenance or repairs should only be done by qualified personnel in a clean environment by following the drawings and parts lists herein.

If leakage occurs through the regulator or out the regulator vent, allow the inlet and outlet pressure to equalize by shutting off the inlet. If leakage continues after the inlet and outlet equalize the vent seat 5 or piston seal 14 are leaking. Replace these. If leakage stops when the inlet and outlet pressure equalize the poppet cartridge item 1 is leaking. Replace this.

**ASSEMBLY & DISASSEMBLY -  
MODEL 873-150 REGULATOR**

ITEM	QTY	PART NO.	DESCRIPTION
1	1	895	poppet assy
2	1	893	body
3	1	879	cap
4	1	894	piston
5	1	946-1	vent seat (vented)
	1	1035-1	seat- not vented
6	1	849	spring guide
7	1	903	cap
8	1	410	spring guide
9	1	378-2	adjusting screw
10	1	379-30	knob
11	2	379-37	bearing plate
12	1	379-38	bearing
13	1	379-5	spring
14	1	876-14	seal (2-137) Vit. 75
15	1	876-15	seal (2-010) Vit. 90
16	1	876-16	seal (2-020) Vit. 90
17	1	876-17	seal (2-140) Vit. 75
18	1or2	952	mount nut - optional
19		979-150	REPAIR KIT - includes items 1,5,14,15,16,17

**NOTES**

1. Technical bulletin - 874  
895 poppet cartridge assy - drw 896
2. Use Dow silicone grease 111 or equivalent on seals and threads. Use Slick 50 EP grease or equivalent on bearings 11 and 12 and on threads between items 7 and 9.
3. **ASSEMBLY**
  - a. Clean all parts and insure there are no visible chips or particulates.
  - b. Inspect vent seat 5 under 10X magnification at sealing edge. Wipe clean as required.
  - c. Install cartridge 1 with seal 16 in housing  
2. Torque to 10 to 20 ft lbs.
  - d. Install seal 14 on piston 4. Pack heavily with dow 111 grease.
  - e. Carefully slide piston 4 into cap 3 as shown.
  - f. Install seal 15 and vent seat 5 into piston as shown.
  - g. Install seal 17 on body 2 as shown.

- h. Screw cap 3 and body 2 together. Hold cap 3 downward so seat 5 does not fall out during assembly. Torque to 10 to 20 ft lbs using a strap wrench or by hand.
- i. Install spring guide 8. then bearing plate 11, then bearing 12, then second bearing plate 11, then spring 13, then spring guide 6 into cap as shown. Use ample Slick 50 EP grease or equivalent on the bearings. Silicone spray can be used to coat these parts and act as a preservative.
- j. Screw cap 7 onto cap 3. Hold cap 7 downward so parts stay in place during assembly. Torque to about 20 ft lbs.
- k. Install adjusting screw 9 and knob 10 as shown using Slick 50 or EP grease.

4. model 873-150NA denotes fixed adjustment and uses a bolt and locking nut instead of items 9 and 10.
5. model 873-150NV denotes non vented regulator.
6. model 873-150L denotes low temp - see assy drw

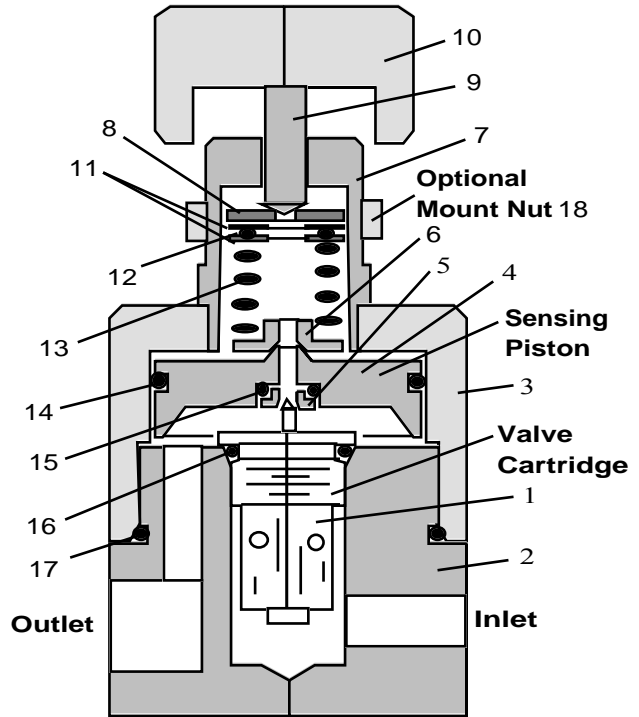

**Model 873-150**