

OPERATION AND MAINTENANCE MODEL 415 REGULATORS

980122 01019;030418D;090519;
090805PS; 091112PS

GENERAL

The model 415 is a piston type, hand load regulator available in outlet pressure ranges of 6000, 5000, 1500, and 400 PSI. It uses an unbalanced poppet design for ruggedness and simplicity. There is a small variation of control pressure with changing inlet pressure as noted in the specifications. A 30 micron filter in the poppet cartridge helps prevent damage by contaminants.

SPECIFICATIONS

Max inlet pressure	6000 PSI
Outlet pressure	50 to 6000 PSI
Body ports	1/4" NPT - inlet and outlet opposite each other plus inlet and outlet gauge ports at 60 degree spacing
Flow coefficient (Cv)	.06 (equals .07" orifice)
Materials	anodized aluminum body, brass and stainless interiors viton & KEL-F seals
Outlet pressure variation with inlet pressure (outlet rise/ inlet drop in PSI)	70/1000 for -5000&6000 22/1000 for -1500 6 /1000 for -400
Model 415B series	brass wetted surfaces see note 7

ASSEMBLY PROCEDURE

1. Refer to drawing 415 cross section and assemble in clean dry area.
2. Blow all parts clean.
3. Inspect sealing area of vent seat item 3 with 10X magnification and remove any particles.
4. Install O ring 13 on piston 4.
5. Completely pack area between piston housing 5 and piston 4 with Cristo lub MCG 121 or 111 or equivalent. Sufficient grease should be used so it takes pressure to extrude grease out as piston is inserted into housing. Wipe off excess.
6. Install O ring 14 with Cristolub 121 or 111 grease and install seat item 3.
7. Apply Slick 50 or equivalent EP grease to bearings 10 and 11, screw 8 and threads in housing 7.
8. Install spring guide 6, bearings 10 and 11, and spring 12 as shown.
9. Install preassembled poppet cartridge item 2, preassembled piston housing and O ring 15 as shown. Lubricate O rings and threads with Cristolub 121 or 111 grease or equivalent.
10. Holding cap downward, assemble cap and body. Torque to 20 to 30 ft lbs.
11. Install adjusting screw and knob with Slick 50 grease on threads.

INSTALLATION

Use a suitable pipe thread sealant such as Teflon tape on inlet and outlet threads. Avoid over torquing pipe thread. Normal torque applied with a 6 or 8 inch long wrench is ample. Use ample Teflon tape - 3 or 4 turns, not 1 or 2 turns. The inlet is on the left when facing the adjusting knob with the two gage ports upward. An optional panel mounting ring is available (part no. 657). The ring clamps to the cap portion of the regulator at any desired location and orientation. The ring has two threaded holes parallel to the regulator spaced 2.8" apart. The regulator is NOT shipped oxygen clean and should NOT be used for oxygen service as provided. Consult the factory for details on oxygen service. **AS WITH ANY REGULATOR, A RELIEF VALVE SET SLIGHTLY ABOVE THE MAXIMUM DESIRED CONTROL PRESSURE SHOULD BE INSTALLED ON THE OUTLET SIDE.**

MAINTENANCE & REPAIR

CAUTION - As with any regulator or valve, particulates or moisture can plug or freeze the internal filter or valve seat. This can occur when up-stream dryers are not changed or remain unused for long periods allowing corrosion materials to accumulate. In critical applications where it is important not to lose flow, a larger particulate filter should be used upstream. Also an orifice such as the Aqua model 796 should be used downstream. This reduces the tendency to freeze when moisture is present. Consult factory for details. The user should establish time intervals for changing the valve cartridge, filter and upstream dryers based on experience and service conditions. No representation is made herein concerning such time intervals as each use is unique. Back-up systems should be used in very critical applications since field maintenance is hard to insure. The poppet cartridge 832 is a factory assembled item and should be replaced if required and not disassembled unless absolutely necessary. Spare cartridges are available at a nominal cost and should be kept on hand if rapid repairs are required. **IN ALL CASES THE UNIT CAN BE RETURNED TO THE FACTORY OR DEALER FOR REPAIR UNDER WARRANTY IF APPLICABLE OR AT A NOMINAL CHARGE.** Maintenance or repairs should only be done by qualified personnel in a clean environment by following the drawings herein.

ASSEMBLY AND DISASSEMBLY

Assembly and disassembly can be done using the following drawings and parts list.

PARTS LIST - 415 REGULATOR

ITEM QTY PART NO. DESCRIPTION

ITEM	QTY	PART NO.	DESCRIPTION
1	1	407	body
2	1	832	poppet cartridge
3	1	726-1	vent seat
	1	1062-1	non-venting seat (optional)
4	1	848	piston for - 5000 & 6000 PSI outlet
	1	947	piston for - 1500 PSI
	1	744	piston for - 400 PSI
5	1	833	piston housing for - 5000 & 6000 PSI outlet version
	1	745	piston housing for - 1500
	1	746	piston housing for - 400 see note 1
6	1	410	spring guide - see note 2
7	1	474	cap
8	1	378-2	adjusting screw
9	1	379-30	knob
10	2	379-37	bearing plate
11	1	379-38	thrust bearing
12	1	379-5	spring
13	1	2-010 -90V	seal for -5000 PSI model
	1	2-015 - 90V	seal for -1500 PSI
	1	2-122 - 75V	seal for - 400 PSI
14	1	2-010 - 90V	seal
15	1	2-028 - 90V	seal for -400 and -1500 only
	1	2-026 - 90V	seal for -5000 (do not use 2-028)
16	1	2-013 - 90V	seal ref.
17	1	849	spring guide, lower
18			not used
19	1	753-19	spring - used only for 6000 PSI outlet version

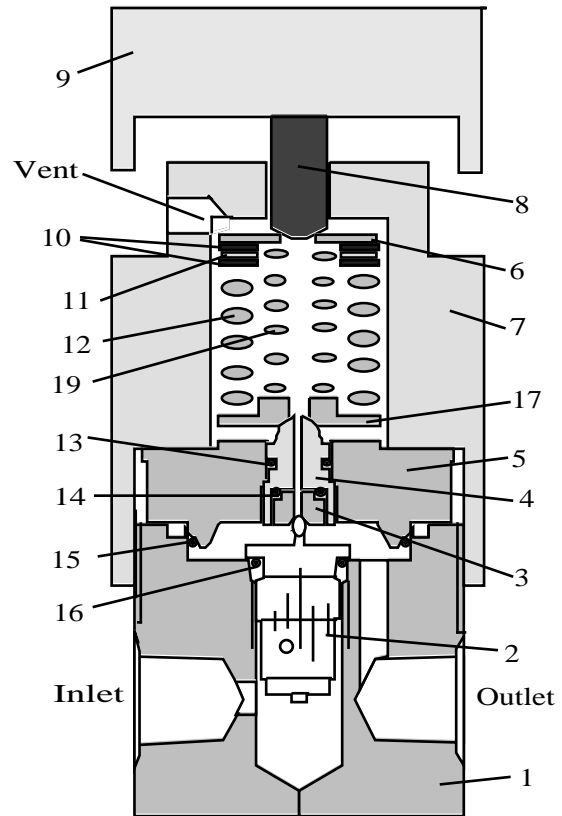

PARTS LIST - 832 POPPET CARTRIDGE

ITEM QTY PART NO. DESCRIPTION

ITEM	QTY	PART NO.	DESCRIPTION
1	1	808	retainer nut
2	1	8016	poppet housing
3	1	809	sleeve
4	1	807	seat
5	1	741	poppet
6	1	2-009 - 90V	seal
7	1	2-013 - 90V	seal
8	1	832-8	spring
9	1	832-9	filter

NOTES

1. Mount piston housing 746 with smoother side downward against seal.
2. mount spring guide 410 with bevel side toward adjusting screw.
3. On 415-400 model mount piston hsg 746 with smooth side toward O ring.
4. Part number 839 -xxxx repair kit includes; 1 ea. 832 cartridge, 1 ea. 2-010 O ring, 1 ea. 2-028 O ring, 1 ea. 726 vent seat, 1 ea. piston and piston O ring. For the -5000 piston hsg 833 is included.
5. Model 415-XXXXNA (non adjustable) - delete items 8 & 9 and replace with 3/8-24 x 1/4" lg. hex head plated bolt and jam nut.
6. Non-vented is 415-XXXXNV and uses p/n1062 as item 3
7. brass version 415B-xxxx items 1,4,& 5 are brass

